

TOSHIBA

Leading Innovation >>>

New ELBRIGHT

TOSHIBA HIGH SPEED ELEVATORS

TOSHIBA
eco style

New ELBRIGHT

TOSHIBA **HIGH SPEED** ELEVATORS

A new concept in high-speed elevators.
 Toshiba never stops introducing the latest technologies and polishing its high-speed elevator expertise. Toshiba proves this again with **New ELBRIGHT** : a new elevator for a new age. Toshiba engineering has combined to produce the world's first inverter-control high-speed elevator, with the high-efficiency control, energy efficiency, and quiet operation demanded by today's society.

Providing environmentally conscious products (New ELBRIGHT)
 Toshiba elevator group is promoting the development of environmentally conscious products, which involves environmentally conscious product design, the assessment of environmental impact of products and disclosure of the environmental performance of products. Products are developed in compliance with the updated voluntary environmental performance standards.

Product assessment and voluntary environmental standards for products
 In developing products, we conduct a product assessment across their life cycles from manufacturing, logistics and use to disposal and recycling in order to conduct product development and reduce the environmental impacts on the global environment. Whereas product assessment is used to confirm the minimum necessary environmentally conscious requirements for product development, Voluntary Environmental Standards for Products have been established in Toshiba elevator group to create highly environmentally friendly products and those products complying with such Standards are released as environmentally conscious products.

■ **Specifications**

Passenger	8~24persons
Rated capacity	600~1800kg
Rated speed	120~240m/min
Driving system	Traction (Gearless)
Control system	Inverter control

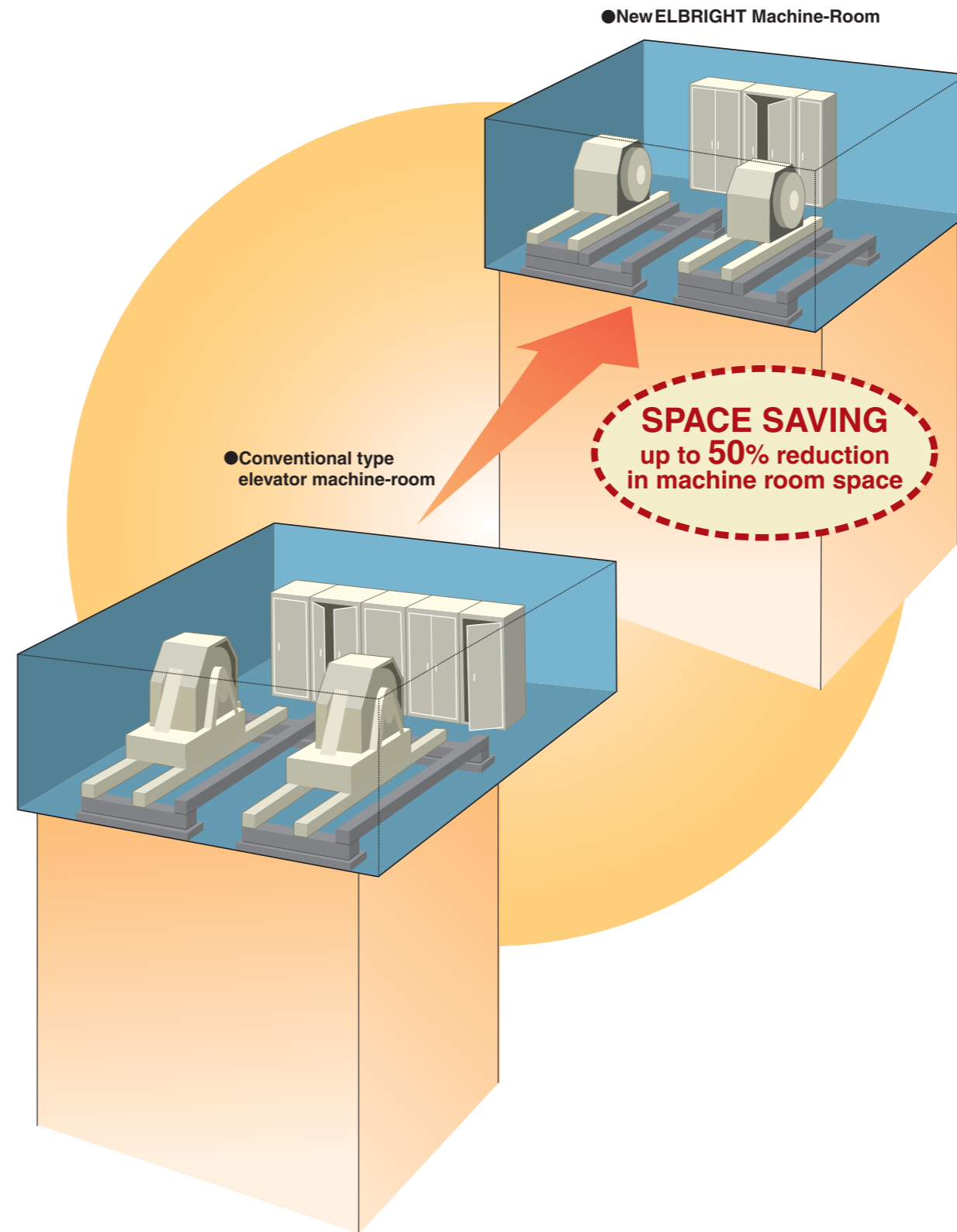

*Comparison with New ELBRIGHT and conventional high-speed elevator.

CONTENTS

PRODUCT CONCEPT
New ELBRIGHT
 Elevator technology .. 3~4

THE GUIDE LINE-1
Traffic planning /
Group control system .. 5~8

- 1-1 Deciding speed 6
- 1-2 Deciding number of cars 6
- 1-3 Deciding passenger capacity 7
- 1-4 Deciding service floors 7
- 1-5 Deciding the layout 7
- 1-6 Operating system 8
- 1-7 Group control system (EJ-1000series) 8

THE GUIDE LINE-2
Soundproofing and
harmonic distortion
measures .. 10~14

- 2-1 Car soundproofing 10
- 2-2 Noise from the elevator impacting the outside 12
- 2-3 Measures against harmonic distortion 14

THE GUIDE LINE-3
Installation plan /
Power facility plan .. 15~22

- 3-1 Installation plan <Standard type> 15
- 3-2 Installation plan <Compact machine room type> 17
- 3-3 Hoistway section 19
- 3-4 Power facility plan 21
- Works by others 22

New technology

Traffic planning/Group control system

Soundproofing and harmonic distortion measures

Installation plan / Power facility plan

A high-efficiency Traction machine and advanced inverter control are expanding the possibilities of

New ELBRIGHT

New ELBRIGHT was developed to be the best possible elevator, both for the buildings in which it is installed and for the people who ride it. Every part of the elevator uses Toshiba's leading technologies, from the Traction machine and control system to the cars, doors, and drive system. New ELBRIGHT will greatly raise the value of the high-speed elevator.

PRODUCT CONCEPT
1

Concept and Energy Efficiency via Permanent Magnet Synchronous Motor

New ELBRIGHT employs a gearless Traction machine using a permanent magnet synchronous motor (PMSM), in place of the conventional induction motor. The PMSM uses a permanent magnet, which has a high magnetic flux density. This allows the Traction machine to be made smaller and lighter. Further more, since a permanent magnetic flux is established, there is no need to release magnetizing current. This and other advantages allow for highly efficient control, which helps to save energy.

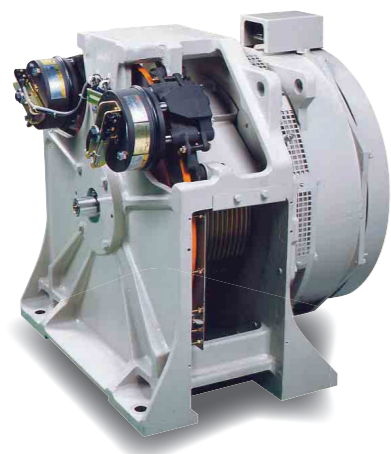

Permanent magnet synchronous motor

Features of the New Traction Machine (comparisons with other Toshiba products)

Footprint	Approx. 60% lower
Height	Approx. 35% lower
Weight	Approx. 40% less
Motor efficiency	Approx. 5% higher

Appearance comparison with conventional Traction machine

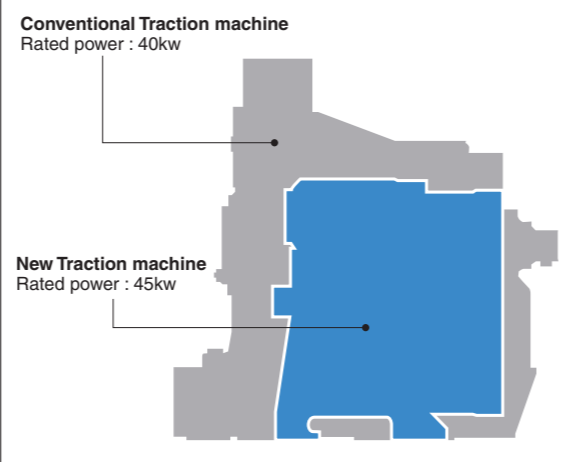

PRODUCT CONCEPT
2

Digital control provides high level of safety and improves control performance

New ELBRIGHT's control system features the "PP7", the latest inverter-control processor developed especially for power electronics. The PP7 improves control performance, and also enhances protection, maintenance and monitoring functionality. Incorporating a 32-bit central processing unit (CPU), peripheral devices, and multi-functional digital circuit in a single package, the PP7 decreases the size of the control system. Toshiba's unique Active Vibration Control and other features give the New ELBRIGHT a speedy, comfortable ride with waste-free, stable running.



PRODUCT CONCEPT
3

Regenerative electric power system

New ELBRIGHT introduces new regenerative electric power system "PWM-converter" for more energy-savings. The combination of PWM-converter and inverter system impressively creates regeneration electric power.

PRODUCT CONCEPT
4

A door drive system developed for smooth operation

The door drive system was developed for smooth operation. Combining the PP7 (the latest inverter-control processor), which is also employed by the Traction machine system, with a compact, high performance motor (permanent magnet synchronous motor). The door drive system not only operates smoothly, it is also lightweight and compact as well.

PRODUCT CONCEPT
5

Newly developed small and slim control panel realizes space-saving machine room.

Toshiba equips New ELBRIGHT's control system with newly developed small inverter unit. Also downsized peripheral equipments, integrated multifunctional digital line, small-sized control panel device and efficiently implemented layout realizes slim line control panel. Additionally, adequately considered design of control panel reduces working space for maintenance and thus space-saving machine room is achieved. Enhanced high-performance control, protective function, maintenance function and supervisory function are significant features and also Toshiba's original cutting edge technology "Active vibration reduction system" provides passengers with efficiently smooth and very comfortable ride.

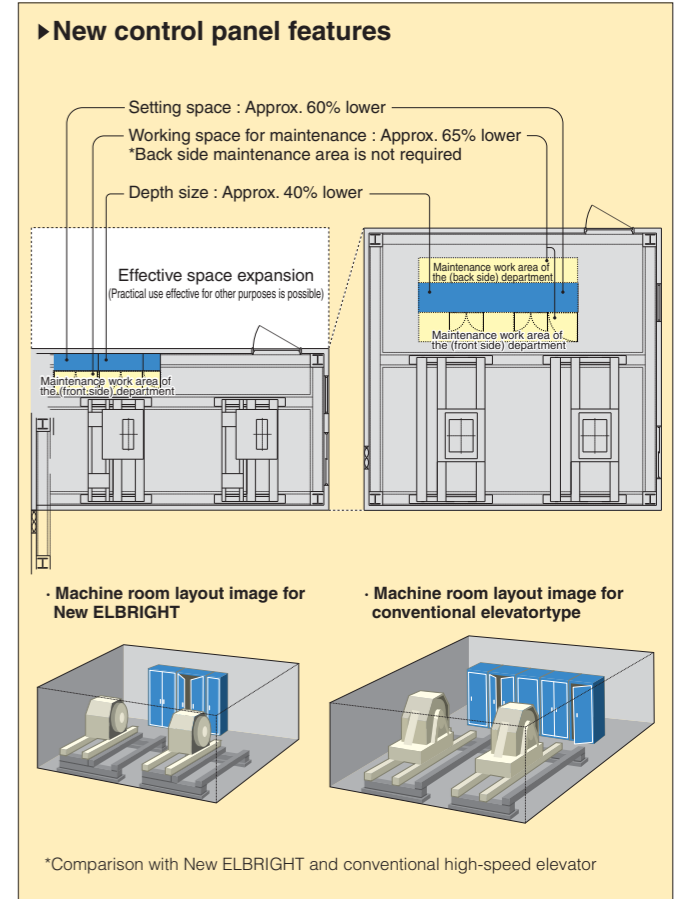

THE GUIDELINE-1

Traffic planning / Group control system

Combining high-precision traffic planning with a building-specification operation plan, New ELBRIGHT offers the optimum system for your building.

The system is able to distinguish between start of office hours, which represent the peak in elevator demand, lunchtime, at which there is a peak in demand for both ascending and descending, and normal service hours, and operate the most efficiently for each type of demand. Additionally, the latest group control system makes multiple elevators work systematically and in partnership, providing operation that is optimal for the building and comfortable for the passengers.

THE GUIDE LINE

1-1 Deciding speed

Elevator speed is generally determined by the number of floor in the building. A general guide is that it should no take more than 30 seconds to travel between the top and bottom floors. Using this basic value, the optimum speed for the building is selected by adding in such factors as the building's purpose, character, and service policy.

Relationship between elevator speed and number of floors in building

Example:
Setting the elevator speed in an office building

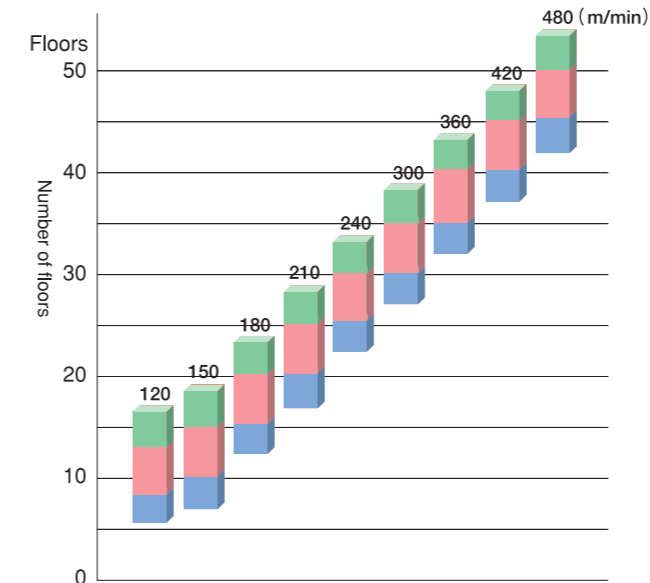

Example:
Setting the elevator speed in a hotel

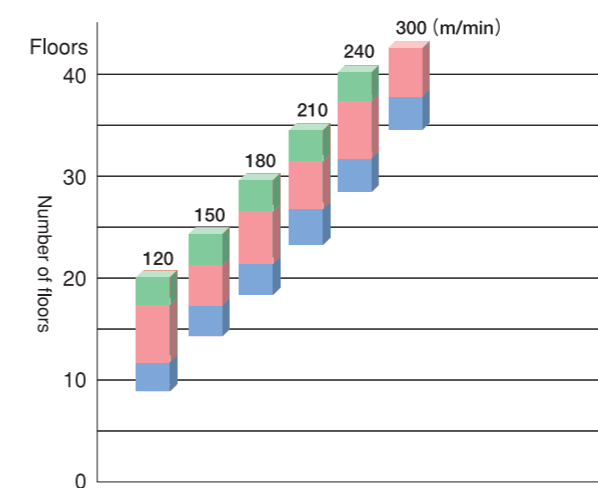

Note: We also support high-speed elevators with speeds exceeding 240 m/min. Please contact us for details.

THE GUIDE LINE

1-2 Deciding number of cars

1. Setting the number of cars

The number of cars is set in order to ensure that the transportation capacity and wait times are maintained within service levels at peak times when there is a concentration of passengers, such as in the mornings and evenings, and during lunchtime. Below is a general guideline for setting the number of elevator cars.

Service Level	Office Building	Hotel
	Number of users per elevator car	Number of rooms per elevator car
Service oriented	150~200passengers	90~120rooms
Standard service	200~250passengers	120~150rooms
Economy oriented	250~300passengers	150~180rooms

Note that for hotel, approximately two-thirds additional cars need to be allowed as service elevators are not included.

2. Traffic calculation

When deciding on the number of elevator cars, passenger capacity, and service floors, traffic calculation provides numerical data for study. The basic values for traffic calculation are shown below.

Office building :
Start of office hours set to be peak for traffic demand

Building Use	Transportation capacity ratio per 5 minutes	Average operation interval
Exclusive owned possession.	20~25%	Service oriented: 30 sec or less
Semi-exclusively owned bldg.	16~20%	Standard service: 40 sec or less
Government bldg.		Economy oriented: 50 sec or less
General office bldg.	11~15%	

Hotel :
Morning hours for check-ins and evening hours when guests leave or go to dinner set to be peak for traffic demand

Hotel Type	Transportation capacity ratio per 5 minutes	Average operation interval
City hotel	8~10%	40 sec or less
Resort hotel	10~13%	50 sec or less

3. Simulation

The building's traffic demand is simulated on a computer, getting a grasp of the state of service including such factors as average wait times and chance of long waits. Combining this simulation with the traffic calculation allows for more accurate planning. The computer mainly outputs normal service status, including peak times. The general base values for the simulation are as follows:

Example : rental office building with demand concentration at 6% of building population per 5 minutes span (during office hours)

- Average wait times : 30sec or less
- Chance of response within 30seconds : 70% or greater
- Chance of response after 60 seconds or more : 5% or less

THE GUIDE LINE

1-3 Deciding passenger capacity

Car passenger capacity must be planned with some leeway for peak times, such as mornings, evenings, and lunchtimes, when use is concentrated, as well as factoring in the nature of the building. We generally recommend the following type of plan:

1. For a small or mid-sized building, passenger capacity of 15 (load capacity of 1000kg) or higher.
For a hotel or large office building, passenger capacity of 24 (load capacity of 1600kg) or higher.
2. Doors should open from the center, and the car entrance should be as wide as possible.
3. The car should be with in relation to its depth

THE GUIDE LINE

1-4 Deciding service floors

Office buildings of more than 20 stories are generally zoned in order to decrease transportation times, improve rental rates, and the like. Zoning refers to dividing elevator service into a number of zones, and installing a dedicated elevator group for each zone. The following point must be taken into consideration in order to make effective use zones.

1. There should be about 10 to 15 floors per zone.
2. In consideration of future movements in tenant population, 2 floors of each service zone should overlap to allow for movement between floors.
3. Post the service floors clearly in order to keep people from getting on the wrong elevator.
4. Keep each elevator at the top or bottom of its service zone.

Unlike office buildings, we recommend staying with a single elevator group for hotels 40 stories or less in order to give top priority to ease of use, in consideration for first-time users. Using a single group does not make passengers select an elevator based on their destination floor, and is also more flexible than zoning, allowing for a number of elevators to be used for special service temporarily, without greatly affecting the passengers. Additionally, if the hotel has banquet halls, a wedding chapel or the like, it is preferable to install a dedicated escalator or elevator for these guests.

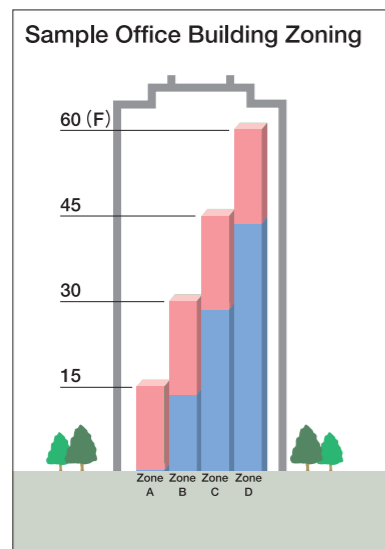

THE GUIDE LINE

1-5 Deciding the layout

Elevator layout has a major influence on building functionality. Thus, the elevator must be laid out to be easy to use and fully harness the elevator's functionality.

1. Position the elevator so that any part of the floor can be reached with little walking, with a focus on lines of movement for traffic.
2. When installing several elevator groups, concentrate each group in a single location.
3. When lining elevators in a row, keep the number of elevators to no more than 4, with at most 8 meters between the elevators on each end.
4. If more than 4 elevators are installed, place them on facing sides of a hallway, with 3.5 to 4.5 meters between them.
5. It must be possible to see all elevators from anywhere in the hall. Avoid constructions with pillars in the elevator hall, and layouts with recessed elevator car entrances.
6. The elevator hall must be large enough that passengers do not spill out even during peak hours. In general, plan the elevator hall large enough to hold about 1/2 the combined maximum capacity of the cars (about 0.5 to 0.8 m² are required per passenger).

Recommend the examples of elevator layout

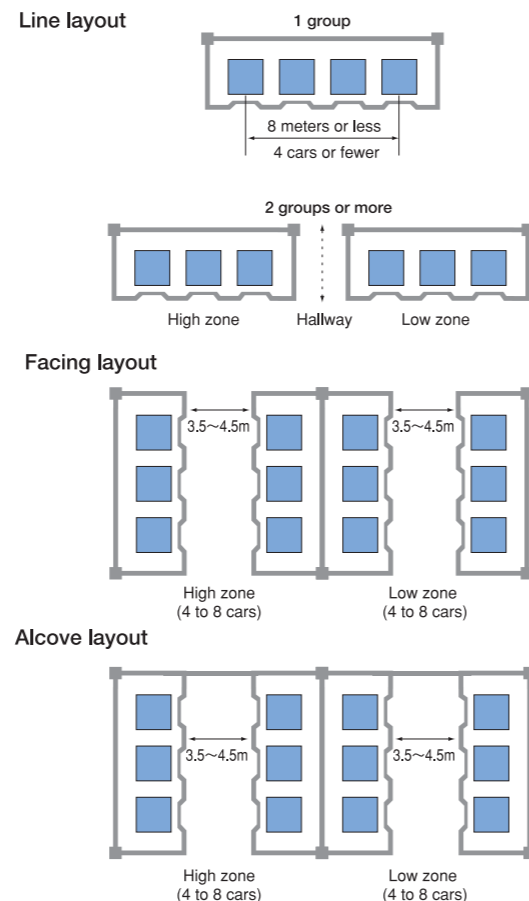

THE GUIDE LINE

1-6 Operating system

Select the operating system based on the building use, number of groups, etc.

Use No. Cars	Building owned by single company	Leased office building		Hotel		Condominium
		Large	Smaller	Large	Smaller	
1	Fully automated collective control	/	Fully automated collective control	/	Fully automated collective control	Fully automated collective control
2	Fully automated duplex collective control		Fully automated duplex collective control		Fully automated duplex collective control	Fully automated duplex collective control
3	Fully automated group control EJ-1000FN EJ-100F	Fully automated group control EJ-1000FN EJ-100F	Fully automated group control EJ-1000FN EJ-100F	Fully automated group control EJ-1000FN EJ-100F	Fully automated group control EJ-1000FN EJ-100F	Fully automated group control EJ-1000FN EJ-100F
4						
5-6						
7-8	Fully automated group control EJ-1000FN	Fully automated group control EJ-1000FN		Fully automated group control EJ-1000FN		

THE GUIDE LINE

1-7 Group control system (EJ-1000series)

EJ-1000FN

The top model in the system, featuring the latest functionality

EJ-100F

Standard system specifications, featuring highly sensitive allocation (fuzzy control) and peak support functions

EJ-10F

Small-scale group control systems, featuring fuzzy control

EJ-1000series specifications

Function	Specification		
	EJ-1000FN	EJ-100F	EJ-10F
Fuzzy neural net control	Yes	Yes	Yes
Learning	Yes	Yes	Yes
Service reservation	Yes	Yes	Yes
Landing voice announcement system	Yes	Yes	Yes
Peak support (assigned operation)	Yes	Yes	Yes
High-sensitivity allocation (fuzzy control)	Yes	Yes	Yes
Expert system	Yes	Yes	Yes
Program modification	Yes	Yes	Yes
No. Cars	3 to 8	3 to 6	3 to 4
Model	EJ-1000FN	EJ-100F	EJ-10F

Specification	Description
Fuzzy neural net control	Automatically learns from changes in elevator operating status to realize the optimum operation for each building.
Learning	Analyzes and stores building-internal traffic demand by time period, and automatically tunes the control parameters used for fuzzy control and the like.
Service reservation	When a hall button is pressed, the elevator hall's lantern comes on, and a single chime sounds.
Landing voice announcement system	The wait time based on group control system operation data is announced at the landing. This makes elevator usage smoother, and puts the people waiting at ease.
Peak support (assigned operation)	Separates elevators into high-floor and low-floor groups at start of business and during lunchtime, to improve transportation capacity.
High-sensitivity allocation (fuzzy control)	Forecasting and identification of operating data, using fuzzy control. Highly sensitive allocation reduces wait times.
Expert system	Specialized experience and expertise are coded into rules, and the optimum rules selected to offer service that best meets humans' psychological needs.
Program modification	Dedicated service staff can hook up a dedicated modification console to the group-control control panel in the elevator machine to modify the program according to elevator use.

THE GUIDELINE-2

Soundproofing and harmonic distortion measures

We reduce noise and suppress harmonic distortion from every angle. We bring together all our technologies and expertise to eliminate the impact of the elevator system.

As buildings become more lightweight and use space more efficiently, minimizing the sound of the running of the elevators and inside the cars has become the most vital point for building planning. We aim to provide a comfortable elevator environment, whose harmonic distortion does not impact other devices.

THE GUIDE LINE

2-1 Car soundproofing

There are 4 main sources of car noise: wind shear, plunge effect, air buffeting, and machine-room noise.

1. Wind shear

When elevators move up and down narrow shafts at high speeds, the air on the side that the car is traveling (see fig. 1 for descending car) becomes compressed. Then as the air pressure rises, the air flows through the gaps between the car and the shaft walls, to the other side of the car. As this air rushes past, it makes a low roaring sound, similar to that of an aircraft passing overhead. This sound is caused by wind shear, and the faster the car is traveling, the louder the noise will be. This sound is striking when an elevator travels at high speeds along a shaft for a single car, or two cars abreast. A particularly loud noise is perceived when two elevator cars in a two-car shaft travel abreast in the same direction. In order to reduce wind-shear noise, it is necessary to reduce the speed at which air passes through the gap between the car and the shaft walls. For example, wind-shear noise will not be generated in a single-car shaft if the elevator's rated speed is 150m/min or less, and it will not be generated in a double-car shaft if the rated speed is 180m/min or less. If speeds above this are an absolute requirement, however, please increase the area of the elevator shaft by 1.4 times the standard dimensions in P.15 (see fig. 2)

Figure 1. Cause of Wind Shear Noise

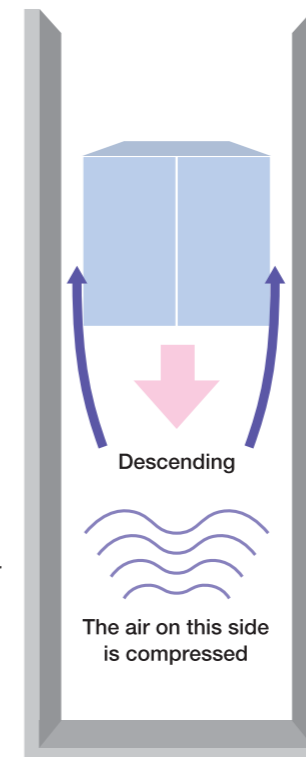
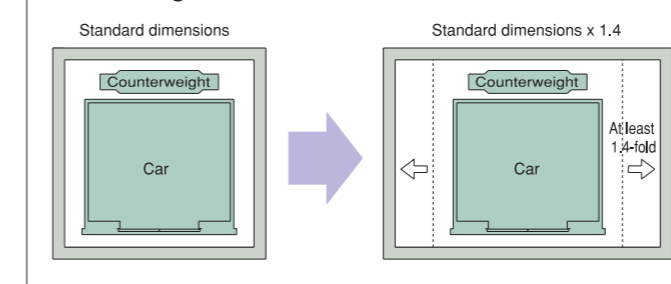

Figure 2. Measures Against Wind Shear



2. Plunge effect

- 1 If multiple elevators are running abreast in a single shaft, and the path of just one of the cars is cut off midway by a wall (fig. 3 shows an example of 3 cars abreast), or if the car paths are staggered in height, then when an elevator enters this relatively more narrow space, the sudden narrowing of the passage causes the air inside the car to become compressed, generating a whooshing sound (fig. 3-1). This is plunge-effect noise. In extreme cases, the noise will be accompanied by a vibration.
- 2 The plunge effect is caused by a rapid rise in air pressure. If this can be prevented, no plunge-effect noise will be generated. The best way of preventing this effect is to not create barrier walls or staggered shafts. If this cannot be avoided due to the building construction, then please implement the following countermeasures. First, creating an air outlet (see fig. 3-2) from the bottom of the barrier wall to the neighboring shaft is effective at preventing this effect. The outlet should be 1.5 to 1.8m², and may be round.
- 3 If you cannot create an air outlet, then the shaft area must be increased 1.4-fold, as with measures against wind shear. Increasing the shaft area in a staggered shaft configuration improves the airflow in this area (fig. 4). However, there is no need for measures to prevent plunge-effect noise for a barrier walls or staggered shafts if the elevator's rated speed is 120m/min or less.

Figure 3. Causes and Measures Against Plunge Effect Noise -1

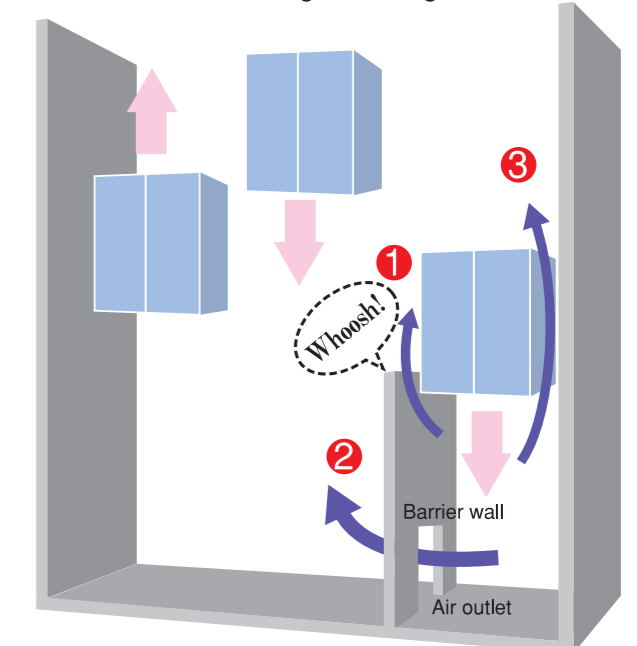
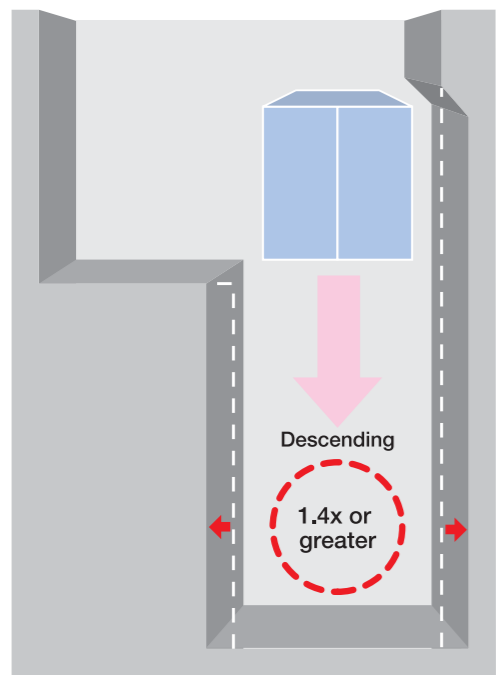

Figure 4.
Causes and Measures Against Plunge Effect Noise-2



■ 3. Buffeting noise

This noise is caused when air being pushed ahead by the car in the shaft hits a protruding separator or other beam. The noise when the compressed air hits the beams sounds something like a “whap”. This is buffeting noise. In buildings with many floors, this sound is heard many times, and becomes noticeable to passengers. In order to prevent this noise, the elevator shaft should be designed with as few protruding surfaces as possible. If there are any protruding surfaces, installing sloped plates is effective at preventing this noise (fig. 5). This measure is required for single-car shafts with a speed of 150m/min or greater, and in dual-car shafts with speeds of 180m/min or greater.

■ 4. Machine room noise

There are several sources of machine-room noise: noise emanating from the hoist or control panel, noise from the turning of the hoist or operation of the brakes, or from the insertion of the electromagnetic contactor. This noise is transmitted into the elevator shaft by the machine-room floor and the rope (main and governor rope) holes, and can sometimes be heard from inside the car. This noise can be prevented by installing glass wool or another soundproofing material on the walls and ceilings of the machine-room, and cinder concrete (150mm or greater) on the floor. This will make the noise from the machine room equipment nearly inaudible from inside the car.

Figure 5.
Causes and Measures Against Air Buffeting Noise

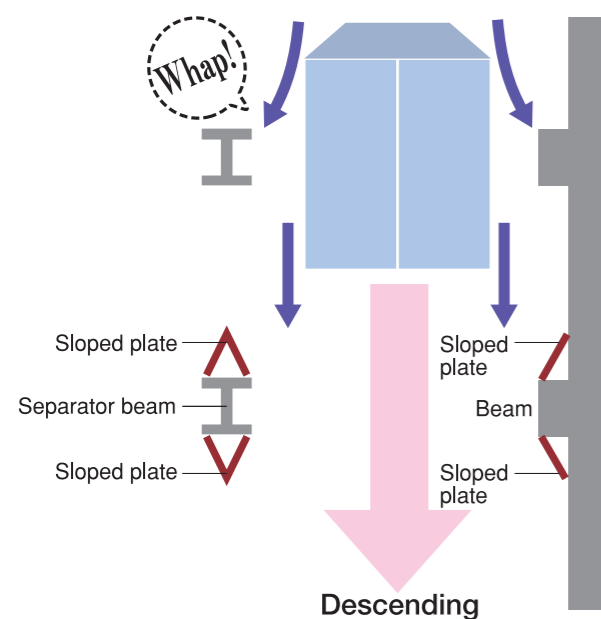
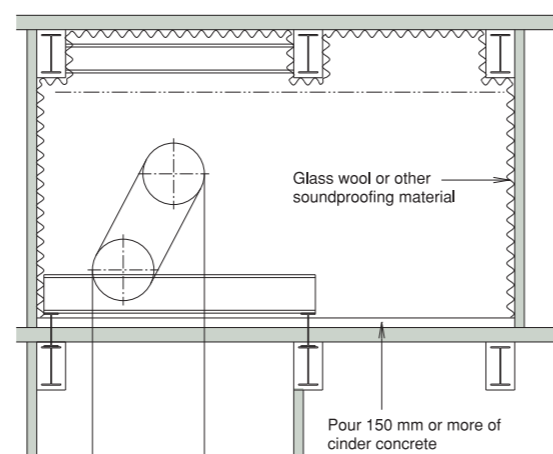

Figure 6.
Measures against Machine Room Equipment Noise



THE GUIDE LINE

2-2 Noise from the elevator impacting the outside

■ 1. Draft noise

When the elevator ascends and descends, a counterweight travels along rails, causing noise. The faster the elevator travels, the louder this noise. Additionally, in high-rise buildings, during the winter months warm air from the heating system flows upward due to the smokestack effect. This affects elevator shafts, since they run vertically through the building, and is particularly severe when the elevator is traveling upward. When the elevator is rising, the rising air will stream through elevator doors on floors opening to the outside, causing a high-pitched howling sound. This noise disturbs the people in the elevator hall and around the shaft of the elevator more than people in the car itself. As described above, this noise is caused when air whistles through gaps in doors and three-side frames. Although this noise can be eliminated by eliminating the gaps in doors and three-side frames, the doors require gaps in order to be opened and closed. Thus, in order to eliminate this noise, it is necessary to give sufficient consideration during the building planning stage. Building planning should take the following 3 points into account:

1. Minimize the entry of outside air into the building by using double doors with a wind-blocking antechamber at building entrances. If double-doors are not possible, then please install revolving doors.
2. Increase the shielding of each floor from outside air, since air infiltrating into the shafts escapes through gaps in the entrances on each floor.
3. Install air conditioning so that the machine-room ventilator draws air upward.

■ 2. Room noise

The following two cases could cause noise from the running of the elevator to be audible from nearby rooms :

1. Wind sheer from the cars can be heard through the shaft walls (air-propagated sound)
2. Sound from the moving counterweight or car is transmitted to the shaft walls via the rails or rail brackets (solid-propagated sound)

The noise from (1) is low, and almost becomes an issue. The sound from (2) can sometimes be perceived in neighboring rooms at levels as high as 50dB (A). The most important thing to do in order to prevent this noise is move the elevator shaft away from rooms susceptible to or highly impacted by noise. You should always take this into account when planning a high-speed elevator. If the shaft cannot be placed away from such rooms, then as shown in fig.7, it is effective to install the rail brackets onto separator beams or back beams, rather than directly to the wall or wall beams.

Figure 7
1. When the room is behind the shaft
(Back-beam insertion example)

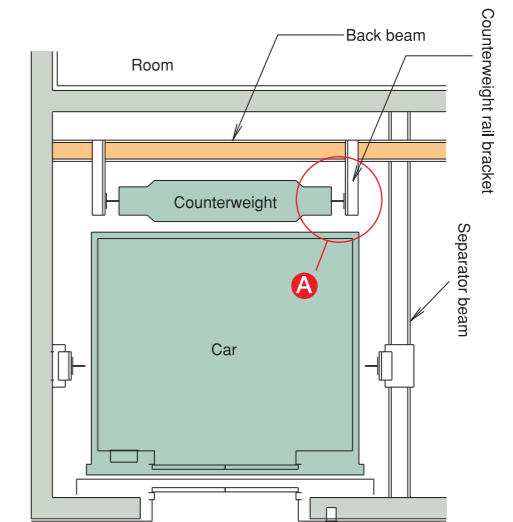

Example of fixing the counterweight rail brackets in A to a separator beam

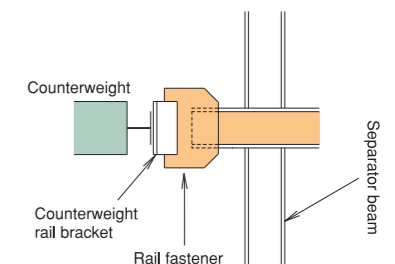

2. When the room is next to the shaft
(Separator beam insertion example)

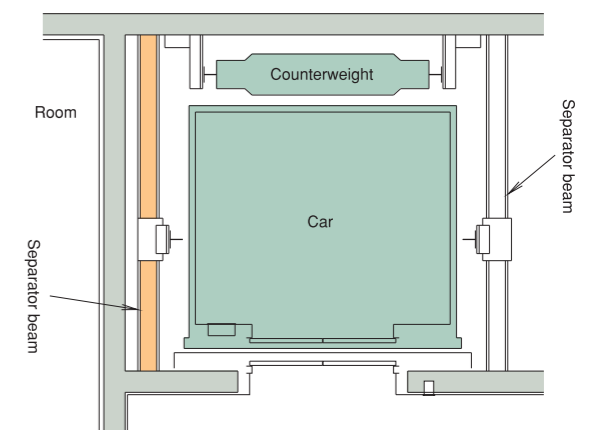

3. Machine room equipment noise

Normally, the elevator's machine room is installed on the building roof, but if service for a given elevator shaft ends on a mid-level floor, then a mid or low-floor elevator machine room is installed inside the building, over that elevator shaft. If such machine rooms can be planned into the building's common space, and surrounded by storage rooms, restrooms, stairwells and the like, then machine room equipment noise will not be a particular issue. However, if the layout requires a room susceptible to or impacted by noise to be separated from the machine room by a single wall only, measures against noise must be taken. As machine-room equipment noise proceeds from the control panel, hoist, and the like, in addition to the soundproofing installed to prevent car noise, please install an airtight soundproof door in the machine room entrance. Additionally, double ceilings or walls may be installed as required.

As described below, there are measures that can be taken to prevent elevator noise inside the cars, and outside the elevator. These measures are extremely effective, and must be incorporated into the building plan. Every case of noise is different, and it is key to approach it from both the building and elevator side. We have provided support for a great number of these unique noise issues. Please consult with us if you foresee noise issues other than the ones listed above.

List of measures against elevator noise

Noise	Measure	
Car noise	Wind sheer	(1) Avoid speeds 180 m/min or greater in single-car shafts, and speeds of 210 m/min or greater in dual-car shafts. (2) If the speeds in (1) cannot be avoided, then make the shaft area 1.4 times the standard dimensions listed in 3-1.
	Plunge effect	(1) Plan around using barrier walls or staggering in part of the elevator shaft. (2) If you must install barrier walls or stagger an elevator shaft ceiling, install a 1.5 to 1.8 m ² ventilation hole in the pit of the barrier wall. (3) If using a staggered shaft, make the area of that shaft 1.4 times the standard dimensions listed in 3.1.
	Air buffeting	(1) Plan to minimize protrusions in the elevator shaft. (2) If the speed of an elevator in a single-car shaft is 150 m/min or higher, or 180 m/min or higher in a dual-car shaft, then install sloped plates over any protrusions.
Noise impacting the areas outside the elevator	Machine-room equipment noise	(1) Install glass wool or other soundproofing on the walls and ceilings of the machine room. (2) Pour 150 mm or more of cinder concrete on the floor.
	Draft noise	(1) Install double doors with a wind-breaking anteroom or a revolving door in the building entrance. (2) Shield each floor from outside air (3) Cool the machine-room via air conditioning
Noise impacting the areas outside the elevator	Tenant room noise	(1) Plan the layout so that the elevator shaft is surrounded by common areas, such as storage rooms, stairwells, and the like (this is particularly essential if the elevator speed is 210 m/min or greater) (2) If the elevator speed is 180 m/min or less and there is no way of isolating the elevator shaft, then install separator beams on the sides of the shaft facing the room, and attach the rails to them.
	Machine-room equipment noise	(1) Plan the floor layout so that the elevator machine room is surrounded by storage rooms, stairwells, and the like. (2) If (1) is not possible, please consult with us. A. Install an airtight, soundproof door on the machine-room entrance B. Apply soundproofing material to the walls and ceiling C. Use double walls and ceilings

THE GUIDE LINE

2-3 Measures against harmonic distortion

Although inverter-control elevators feature high-performance, high energy efficiency, and other benefits, they use high-speed switching elements, which generate harmonic distortion when operating, which could impact telecommunications and office-automation equipment. Please take the following measures to avoid impact from harmonic distortion.

1. Install the elevator drive power transformers away from the transformers of telecommunications devices, office automation equipment, and other low-power electronic devices.
If you draw power for low-power electronic devices from the same transformer as the drive power, the harmonic distortion generated by the elevator could cause condition noise, impacting the low-power electronic devices.
2. Keep elevator drive power lines at least 1m away from the power lines and communications lines of low-power electronic devices.
Electromagnetic and electrostatic induction is effective at reducing noise. If it is not feasible to keep the lines separated, then separate the drive power lines from the lines of the low-power electronic devices using a steel shielding plate.
3. Do not install elevator power lines in the ceilings or floors near low-power electronic devices.
Electromagnetic and electrostatic induction is effective at reducing noise. Avoid cabling near low-power electronic devices, and keep lines as short as possible.
4. Avoid using the same earth for low-power electronic devices.
Conduction, and electromagnetic and electrostatic induction are effective at reducing noise.
5. If you install a residual current operated circuit breaker or electric leakage magnetic relay, use one with inverter support in order to avoid excessive operation.
Inverter-control elevators release leak current, which causes excessive operation by residual current operated circuit breakers and electric leakage magnetic relays. Please use an inverter-compliant product that does not operate needlessly in the high-frequency range.

Sample earth line layout

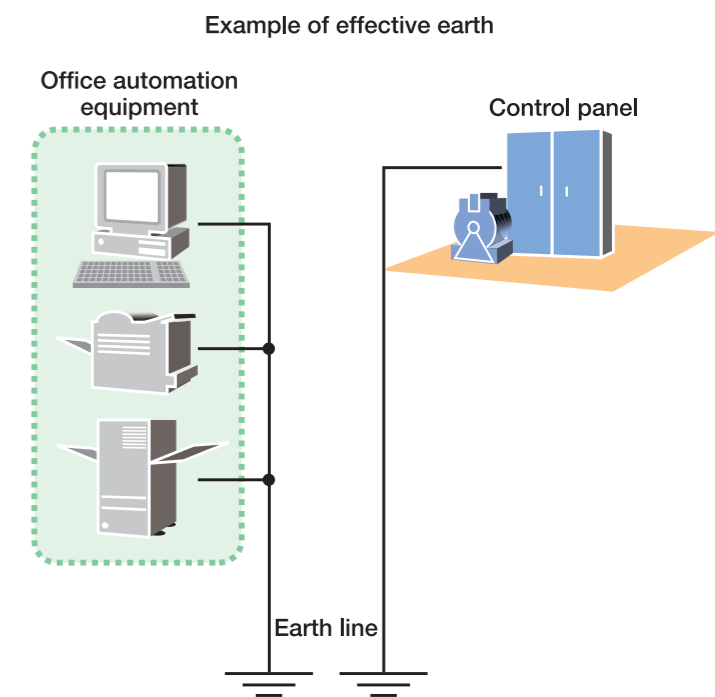
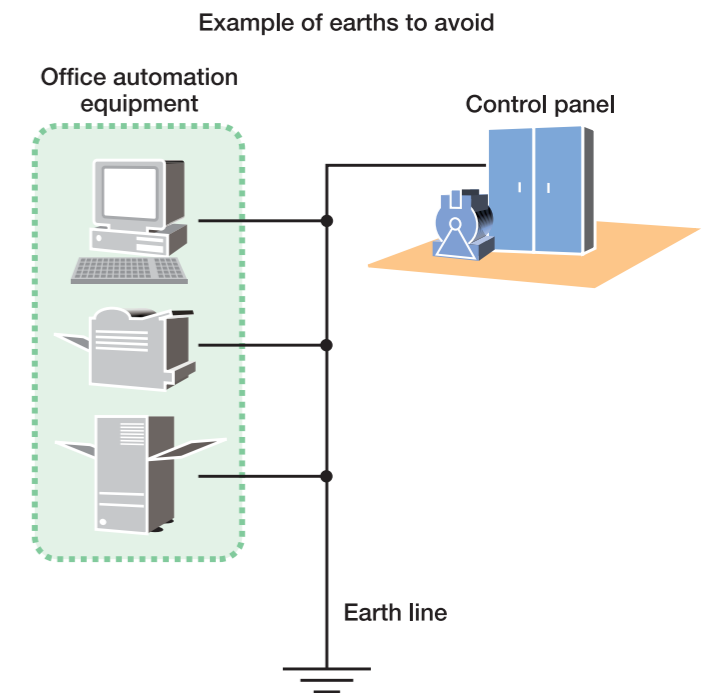

3-1 Installation plan <Standard type>

Installation diagram for 8 to 24 passenger

■ Hoist-way plan

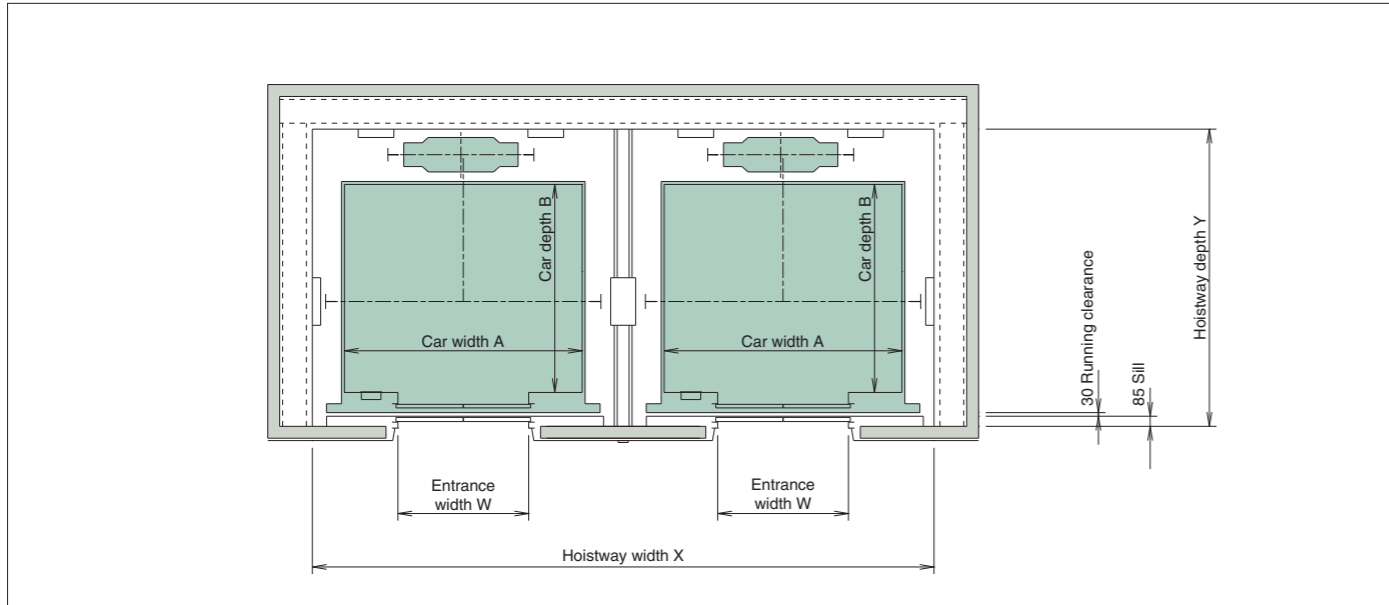

■ Machine-room plan

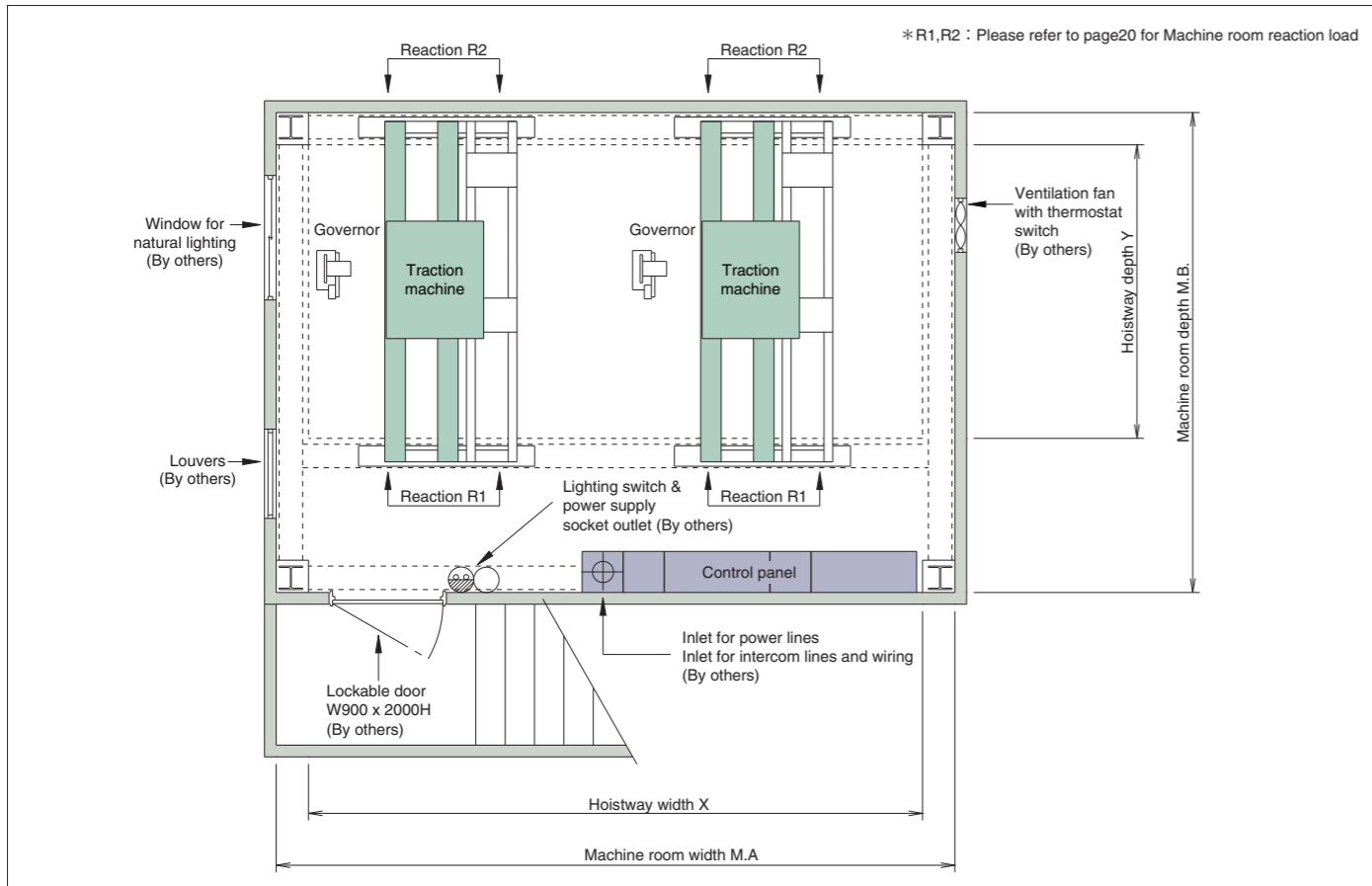

■ Shaft and machine room dimensions (Floor plan dimensions)

Rated speed (m/min)	Type	Entrance (mm)		Internal car dimensions (mm) AxB	Shaft (mm)				Machine room (mm)			
		Width	Height		Single shaft* X x Y	Dual shaft** X x Y	Triple shaft X x Y	Quadruple shaft X x Y	Single shaft* MA x MB	Dual shaft** MA x MB	Triple shaft MA x MB	Quadruple shaft MA x MB
120	P8-CO	800	2100	1400x1100	1940x1925	4030x1925	6120x1925	8210x1925	2350x3400	4500x3400	7000x3400	9150x3400
	P12-CO	900	2100	1600x1350	2140x2175	4430x2175	6720x2175	9010x2175	2500x3650	4800x3650	7450x3650	9750x3650
	P13-CO	900	2100	1600x1500	2140x2325	4430x2325	6720x2325	9010x2325	2500x3800	4800x3800	7450x3800	9750x3800
180	P15-CO	1000	2100	1800x1500	2340x2325	4830x2325	7320x2325	9810x2325	2700x3800	5200x3800	8050x3800	10550x3800
210	P18-CO	1000	2100	2000x1500	2540x2325	5230x2325	7920x2325	10610x2325	2900x3800	5600x3800	8650x3800	11350x3800
	P24-CO	1200	2100	2100x1750	2640x2575	5430x2575	8220x2575	11010x2575	3050x4050	5900x4050	9100x4050	11950x4050

* In order to prevent noise in the car for a single-shaft elevator with a speed of 180 m/min or greater, increase the dimensions of the shaft X and machine room MA.
 ** In order to prevent noise in the car for a double-shaft elevator with a speed of 210 m/min or greater, increase the dimensions of the shaft X and machine room MA.
 Note: Please contact us for detailed dimensions.

3-2 Installation plan <Compact machine room type>

Installation diagram for 8 to 24 passenger

Hoist-way plan

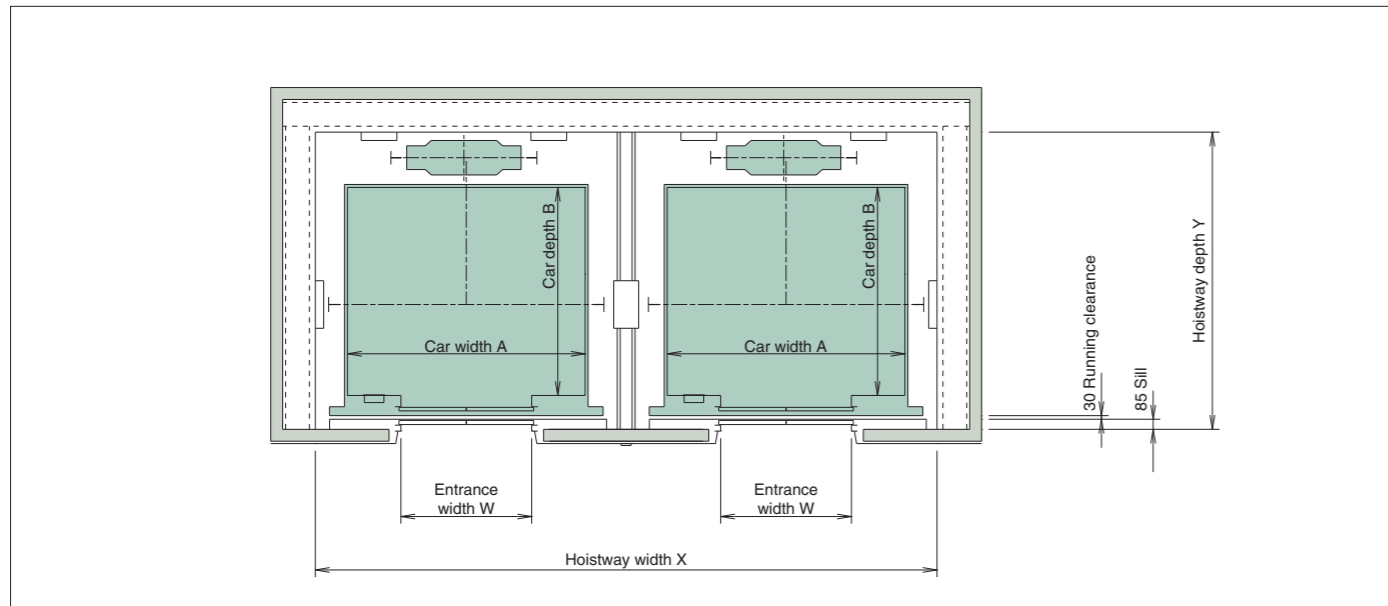

Machine-room plan

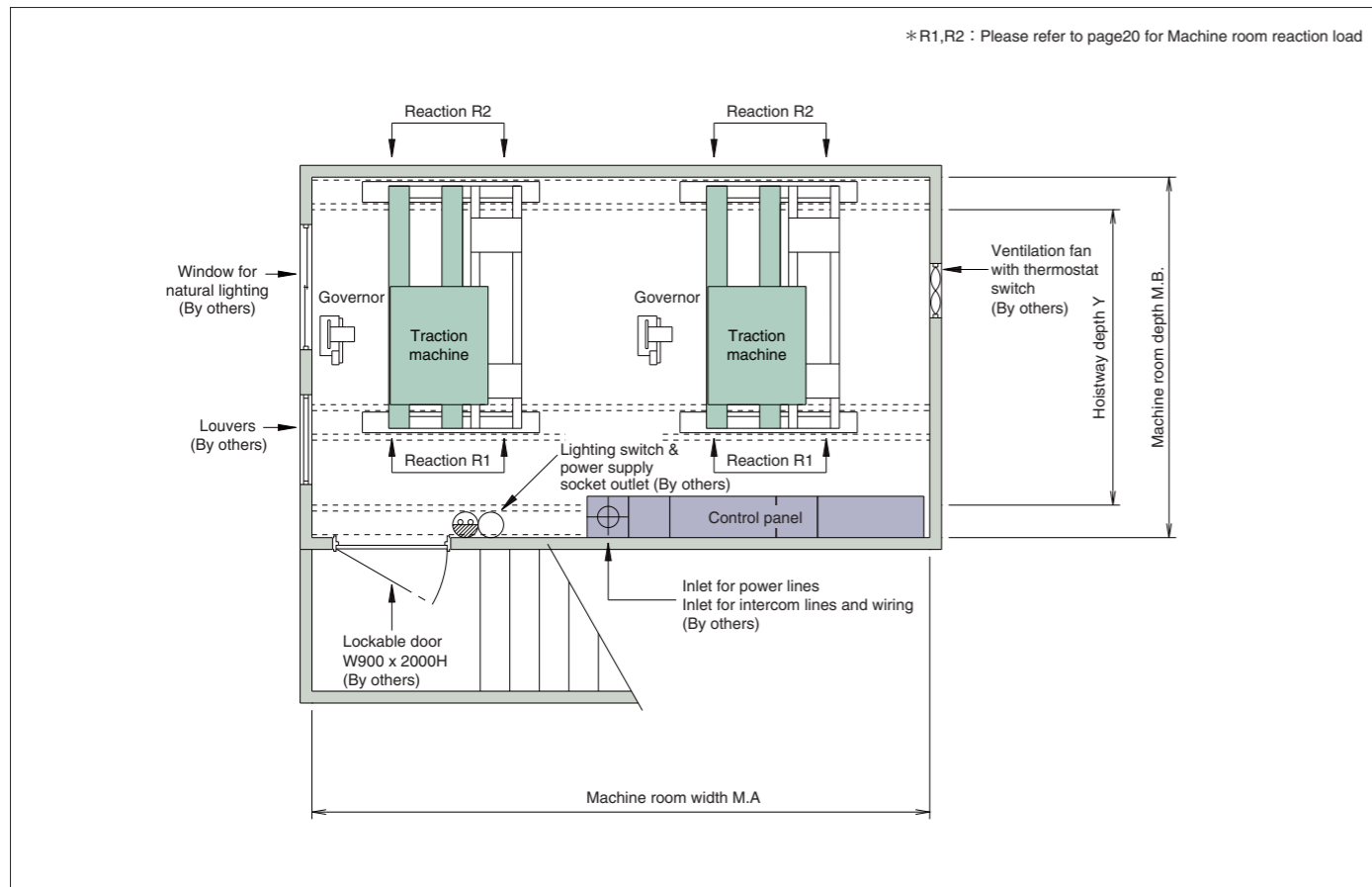

Shaft and machine room dimensions (Floor plan dimensions)

Rated speed (m/min)	Type	Entrance (mm)		Internal car dimensions (mm) AxB	Shaft (mm)				Machine room (mm)			
		Width	Height		Single shaft* X x Y	Dual shaft** X x Y	Triple shaft X x Y	Quadruple shaft X x Y	Single shaft* MA x MB	Dual shaft** MA x MB	Triple shaft MA x MB	Quadruple shaft MA x MB
120	P8-CO	800	2100	1400x1100	1940x1925	4030x1925	6120x1925	8210x1925	2100x2750	4230x2750	6370x2750	8610x2750
	P12-CO	900	2100	1600x1350	2140x2175	4430x2175	6720x2175	9010x2175	2250x2850	4430x2850	6720x2850	9010x2850
	P13-CO	900	2100	1600x1500	2140x2325	4430x2325	6720x2325	9010x2325	2250x2950	4430x2950	6720x2850	9010x2950
150	P15-CO	1000	2100	1800x1500	2340x2325	4830x2325	7320x2325	9810x2325	2700x2950	5200x2950	8050x2950	10550x2950
180	P18-CO	1000	2100	2000x1500	2540x2325	5230x2325	7920x2325	10610x2325	2900x2950	5600x2950	8650x2950	11350x2950
	P21-CO	1100	2100	2000x1700	2540x2525	5230x2525	7920x2525	10610x2525	2900x3050	5600x3050	8650x3050	11350x3050
	P24-CO	1200	2100	2100x1750	2640x2575	5430x2575	8220x2575	11010x2575	3050x3050	5900x3050	9100x3050	11950x3050

* In order to prevent noise in the car for a single-shaft elevator with a speed of 180 m/min or greater, increase the dimensions of the shaft X and machine room MA.
 ** In order to prevent noise in the car for a double-shaft elevator with a speed of 210 m/min or greater, increase the dimensions of the shaft X and machine room MA.
 Note: Please contact us for detailed dimensions.

3-3 Hoistway section

■ Hoistway section <Standard type>

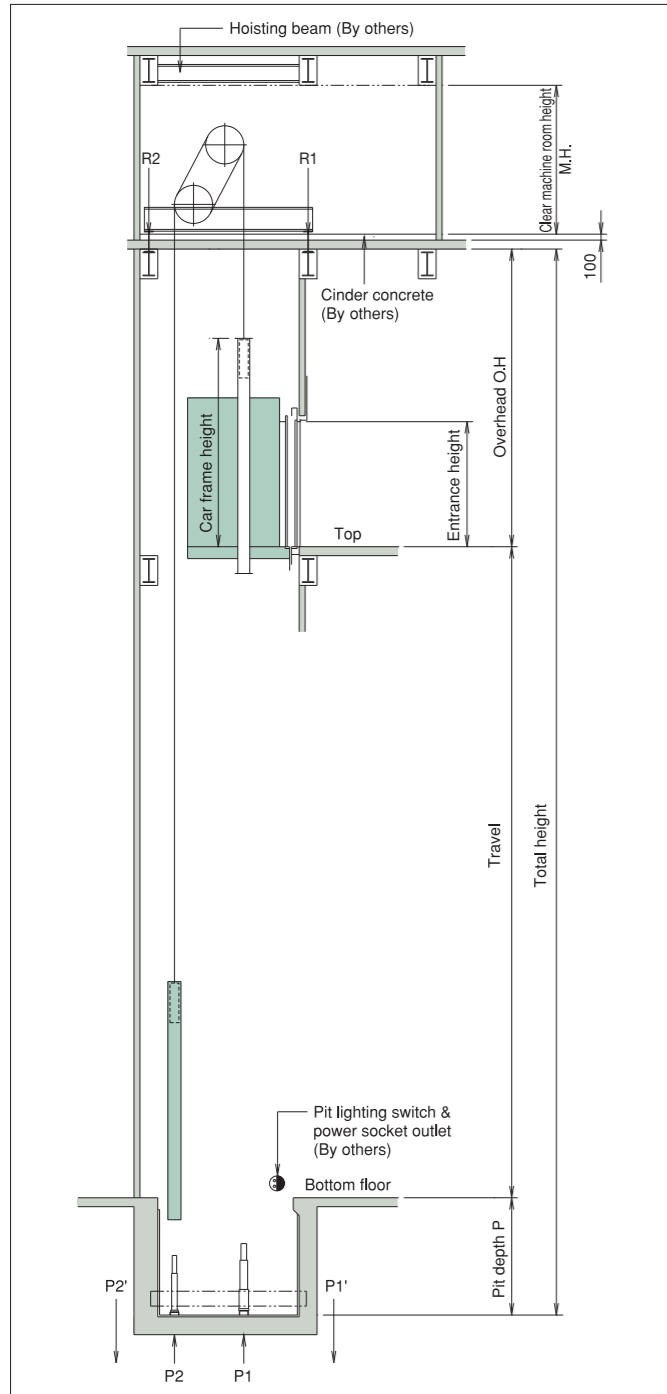

■ Hoistway section <Compact machine room type>

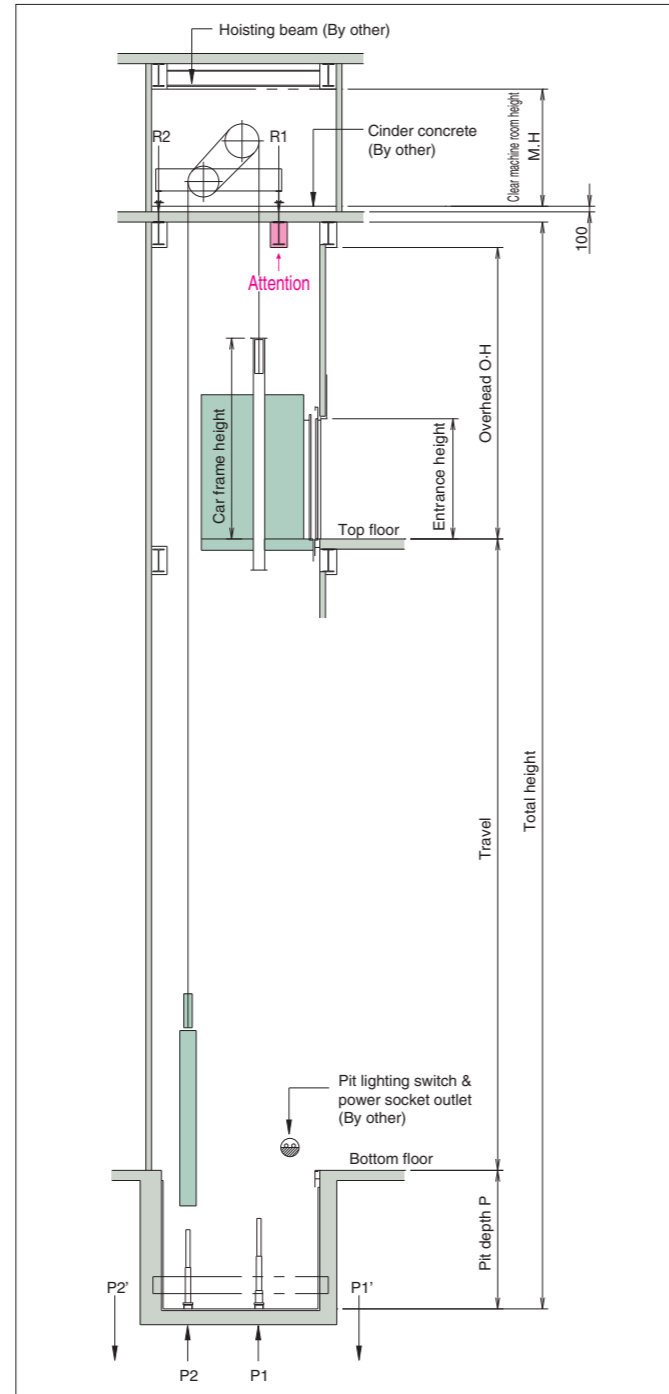

Note :
When car safety is suddenly actuated or when car strikes against buffers during high-speed operation, the counterweight will jump up. Likewise when the counterweight safety (where provided) is actuated or when it strikes the buffer, the car will also jump up. Hence for the elevators with speed of 240m/min or higher, tie-down safety device is provided at the compensating sheave to reduce the jumping effect of the car and counterweight by absorbing the jumping energy into the springs of the tie-down safety and elastic strain energy of the compensating ropes.

■ Shaft & Machine room dimensions (Cross section dimensions)

Rated speed (m/min)	Overhead		Pit depth P(mm)	Clear machine room height M.H.(mm)
	O.H.(mm)			
	P8,P12	Other		
120	5950	5350	2150	2250
150	6150	5550	2450	
180	6450	5850	2750	
210	6850	6250	3250	
240	7450	6850	3850	

Note: Dimensions are displayed with a leeway of 50 mm. Impact force applied to machine-room reactive-force pit, force applied to tie-down safety, and force applied to machine-room ceiling trolley beam.

■ Machine room reaction, pit reaction, tie-down safety and hoisting beam load.

Type	Rated speed (m/min)	Machine room reaction load (kN)				Pit reaction load (kN)		Tie-down safety reaction load (kN)		Hoisting beam load (kN)
		Standard type		Compact machine room type		P1(Cage)	P2(C/W)	P1'(Cage)	P2'(C/W)	
		R1(Cage)	R2(C/W)	R1(Cage)	R2(C/W)					
P8-CO	120	95.5	132.5	134.0	94.0	194.0	172.5	-	-	54.0
	150					195.5	173.5	-	-	
	180					195.5	173.5	-	-	
	210					195.5	173.5	-	-	
P12-CO	120	106.0	147.0	153.0	99.5	211.5	184.0	-	-	
	150					220.0	192.5	-	-	
	180					220.0	192.5	-	-	
	210					220.0	192.5	-	-	
P13-CO	120	107.5	150.5	157.5	100.5	225.0	195.5	-	-	
	150					226.0	196.5	-	-	
	180					226.0	196.5	-	-	
	210					226.0	196.5	-	-	
P15-CO	120	110.5	155.0	162.0	104.0	232.5	203.0	20.0	48.5	
	150					232.5	200.5	-	-	
	180					232.5	200.5	-	-	
	210					234.0	201.5	-	-	
P18-CO	120	113.5	159.0	167.0	105.5	240.5	208.0	21.0	48.5	
	150					244.5	208.5	-	-	
	180					244.5	208.5	-	-	
	210					245.5	209.5	-	-	
P21-CO	120	118.0	165.5	173.0	110.5	252.0	216.0	20.5	50.0	
	150					265.5	224.5	-	-	
	180					265.5	224.5	-	-	
	210					266.5	225.5	-	-	
P24-CO	120	123.5	173.0	183.0	113.5	265.5	224.5	-	-	
	150					273.5	232.0	22.5	61.5	
	180					273.5	232.0	22.5	61.5	
	210					278.5	233.0	-	-	
P24-CO	120	128.5	179.0	190.0	117.5	277.5	232.0	-	-	
	150					285.0	240.0	21.5	63.0	
	180					285.0	240.0	21.5	63.0	
	210					285.0	240.0	21.5	63.0	

Values may differ slightly, depending on car design and car-room size. Please contact us for details.

■ Attention <Compact machine room type>

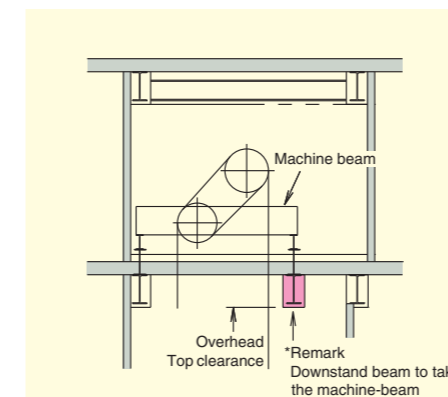

- ① Provision of a downstand beam is necessary to take the loading
- ② Please ensure sufficient clearance for overhead and top clearance
- ③ Please consult the structural engineer on the design of the downstand beam.
- ④ Downstand beam to be provided by others.

3-4 Power facility plan

Power facility plan for 8 to 24 passenger

Single elevator use (1 line per elevator) 380v-50Hz

Model	Rated speed (m/min)	Motor capacity (kW)	Motor source capacity (kVA)	Non-fuse circuit breaker (A)	Total applicable length of the power source line (m)					Grounding line size (mm ²)	Heat generation (W)
					5.5 (mm ²)	8 (mm ²)	14 (mm ²)	22 (mm ²)	38 (mm ²)		
P8-CO	120	8	14	40	58	90	160	250	423	3.5	2050
	150	10	16	40	46	71	126	198	334	3.5	2600
	180	12	18	40	38	58	104	163	276	3.5	3100
	210	14	20	50	32	50	90	141	238	3.5	3600
	240	16	22	50	28	44	78	122	207	3.5	4100
P12-CO	120	12	18	40	50	77	138	215	364	3.5	3100
	150	14	21	50	39	61	109	170	288	3.5	3850
	180	18	25	60	33	51	91	142	241	5.5	4600
	210	20	28	60	-	40	77	120	203	5.5	5400
	240	22	31	75	-	35	67	105	177	5.5	6150
P13-CO	120	12	19	50	48	74	133	208	351	3.5	3450
	150	16	23	50	38	58	104	163	276	3.5	4300
	180	18	27	60	-	45	86	135	228	5.5	5150
	210	22	30	75	-	38	74	115	195	5.5	6000
	240	24	34	75	-	-	59	99	168	5.5	6850
P15-CO	120	14	22	50	45	70	124	195	329	3.5	3950
	150	18	26	60	-	52	99	155	262	5.5	4900
	180	22	30	60	-	42	81	128	216	5.5	5900
	210	26	34	75	-	-	64	108	183	5.5	6850
	240	28	38	100	-	-	55	93	158	5.5	7850
P18-CO	120	18	25	60	41	65	115	180	305	5.5	4600
	150	22	29	60	-	47	91	142	241	5.5	5750
	180	26	34	75	-	-	70	118	199	5.5	6900
	210	30	39	100	-	-	60	101	171	5.5	8050
	240	34	44	100	-	-	51	86	146	5.5	9200
P21-CO	120	20	28	60	-	55	106	166	280	5.5	5450
	150	24	34	75	-	-	77	130	220	5.5	6850
	180	30	40	100	-	-	64	107	182	5.5	8200
	210	34	45	125	-	-	54	91	153	8	9550
	240	40	51	125	-	-	46	78	133	8	10900
P24-CO	120	22	31	75	-	52	100	157	266	5.5	6150
	150	28	38	100	-	-	73	122	207	5.5	7700
	180	34	44	100	-	-	59	100	170	5.5	9200
	210	38	51	125	-	-	51	85	145	8	10750
	240	44	57	125	-	-	-	69	125	8	12300

Works by others

Works below are not included in installation works of elevator:

Hoistways

- Hoistway construction and fire-proofing work, and opening work for jambs, indicators and push-buttons, etc. Please note that chipping or padding work is required according to the necessity, in case the error of the structure is 30 mm or over.
- Installation work of separating beams, intermediate beam, back beam and lateral beams (If necessary).
- Installation work of the base plate for each floor and of bed steel for furnishing the equipments related to landing entrance, in case of hoistways of steel structure of PC structure.
- Fire-proofing work of steel frame material in steel structured hoistways, and fire-proofing work around landing entrances (If necessary).
- Finishing works of walls and floors, etc., around entrances, after furnishing equipments related to landing entrances.
- Furnishing work of base steel or others for furnishing rail brackets, especially in case the floor height is high (if necessary).
- Installation work of the entrance or the gangway for pit inspection (if necessary).
- Water-proofing work of the pit (including drainage if necessary).
- Re-arrangement of the building body in case that there are some spaces to be used under the pit.
- Installation work of emergency exits for rescue purposes in the event there are floors at which the elevator does not stop and installation of a fascia plate.
- Shelter equipments from rain at landing entrances directly contacting to the air in the place like roof.
- Installation work of hooks or beams on top of the elevator shaft.
- Installation work of lighting in hoistway (If necessary).
- Installation work of vent opening at the top of shaft (If necessary).
- Installation work of a net or wall to prevent falling into the pit (in case of pit level is different.)
- All works related to the building structure other than works above.

Machine rooms

- Construction work of machine-rooms and installation works of their entrances (including sound proofing work if necessary)
- Fire-proofing work for machine rooms and opening work for machine room floors.
- Installation work of machine beam supports and spacers.
- Cinder concreting and its finishing work after floor piping in machine rooms.
- Installation work of hooks or beams on ceilings in machine rooms.
- Installation work of stairs leading to machine rooms and stairs in machine rooms (if necessary)
- Installation work of lighting windows.
- Dust-proof finish of the floor.

Works for Equipments

- Wiring work of the power supply for motors and that for lighting equipments, and of grounding to power source panels of elevators in the Elevator shaft.
- Wiring work of the power supply to the supervisory panels.
- Piping and wiring works of interphones outside hoistway and of others necessary for elevators.
- Supply and installation of switching devices for emergency power supply at the power failure and two pairs of relay contacts for normal / emergency power identification, and their piping and wiring work (if necessary).
- Piping and wiring work of supervisory panels, alarm panels and inter-communication systems, etc., outside hoistways.
- Furnishing work of receptacles for inspection in pits.

Temporary Works

It is required to arrange the following matters:

- To secure the site office for installation work, and the stock yard for materials without charge.
- Enclosure to be used during the installation work.
- Supply of electric power for installation work and the trial operation for adjustment.
- Security of enough passage for carrying heavy goods.
- On use of elevator for the construction work of the building, it is required to make contract with a separate written estimate.

Note

At equipment planning of elevators, please take the following items into consideration:

- Provide the power facility so that the voltage regulation of power supply at the receiving terminals in the hoistway is kept within $\pm 10\%$ for motor, and $\pm 2\%$ for lighting equipments.
- In the hoistways, please avoid allowing the temperature exceed 40 °C and humidity exceed 90% (monthly mean) and 95% (daily mean).
- Please do not allow such chemically toxic gas or excess amount of dust enter into the hoistways, that makes the metal or electrical contacts corrode.

At inquiry of the estimate, please inform us of the following:

- Building name and address.
- Desired type and number of set.
- Number of stops.
- Floor height.
- Voltage and frequency of main power supply.
- Desired completion date.



Safety Cautions

- Observance of relevant laws / regulations are required.
- Read the entire "Instruction Manual" carefully before use, for important information about safety, handling and operation.

TOSHIBA

TOSHIBA ELEVATOR AND BUILDING SYSTEMS CORPORATION

72-34, Horikawa-cho, Saiwai-ku Kawasaki, 212-8585, Japan
PHONE: +81-44-331-7057, FAX: +81-44-548-9597

- The data given in this catalog are subject to change without notice.