

TOSHIBA
Leading Innovation >>>

For managers in charge of operation
TOSHIBA TE series escalator

Kindmover Instruction Manual

For Operation Management



E s c a l a t o r

Please read this instruction manual carefully before the operation
for its correct and secure use,
and keep the manual handy for future reference.

Introduction

Thank you very much for using TOSHIBA escalators. In order to ensure the elevator operates safely, maintenance is required. However, regular inspection by the operator on daily basis is necessary too.

Please assign an operator, who is directly in-charge of the operation of escalators.

To ensure an elevator is operated correctly and safely, the operator must read through this “Instruction Manual” carefully before the operation.

After finished reading this manual, please place it within reach of the operator.

When the owner or the operator changes, please make sure that this manual is hand over to the next operator.

If you find any question or incomprehensible descriptions, please direct all inquiry to your nearest Toshiba office listed at the end of this manual.

This manual is intended to be used as a guide of maintenance and operation of Toshiba escalator “Kindmover”.

Terms and Definitions

An Owner is the person who owns the escalator.

An Operator is the person who is directly in-charge of the operation of escalators in use.

An engineer is the person within professional qualification, who is in-charge of the maintenance of the escalator.

Kindly sign up the maintenance contract with TOSHIBA ELEVATOR AND BILDING SYSTEMS CORPORATION. We assure you the satisfaca-tion of high quality maintenance services.

Ensure quality performance and operation of your escalator.

- We understand the overall structure of the elevator clearly, including the design, manufacture, sales, installation, and maintenance, the correct technical information. Thus, our service is quality assurance.
- Records of use, defects, part replacements, repairs, inspections and other data are maintained in computers escalator by escalator. Thus, we can offer maintenance and inspection systematically and efficiently.

Ensure efficient repair and parts replacement.

- We supply appropriate parts according to the model and have all of them ready in stock. Repair service and part replacement can be done efficiently.

Quick action service is possible.

- In case of malfunction or emergency, our engineers are able to fix the problem in timely manner.

Take charge by professionals.

- Your elevator is always maintained by professionals. Only engineers who possess professional skills and qualification will be assigned to take charge of the escalator's maintenance.

Contents

Introduction	1
Safety precautions.....	3
Safety precautions to be observed.....	4
Explanation of safety devices.....	11
Name and function of each part	13
Explanation of basic operation	15
Start operation.....	15
Stop operation	16
Explanation of how to use for passengers	17
Example of an ESNAPI display	18
When the escalator is normally operated.....	18
When anomalies occur and the escalator stops.....	18
Measures in case of emergency.....	19
When an emergency stop occurs	19
When an accident resulting in injury or death occurs	20
Example of the rescue method.....	20
Measures in case of disaster.....	21
When an earthquake occurs.....	21
When a fire breaks out.....	22
When a preliminary announcement of power failure is made	23
When a typhoon (local severe rain) approaches.....	24
Notice for daily check.....	25
How to clean up and maintain.....	27
Guidelines on the Maintenance and Operation of Escalators	29





Definition of safety sign

This instruction manual includes important details to help avoid injuries for the supervisor, escalator users and others, so that the product can be operated safely and correctly.

Understand the following signs, symbols and their meanings, then read this manual. Follow all descriptions.

Description of signs



Sign	Meaning of sign
 DANGER	Indicates "If erroneously handled, person may die or be seriously injured", and the degree of urgency imminence is high.
 WARNING	Indicates "If erroneously handled, person may die or be seriously injured *1".
 CAUTION	Indicates "If erroneously handled, person may be injured*2 only material damage*3 may occur".

*1: "Seriously injured" means blindness, injury, burn (high-temperature and moderate-temperature), electric shock, fractures, poisoning, etc. with long-lasting effects or that require hospitalization and/or long-term hospital visits for treatments.

*2: "Injured" means an injury, burn, electric shock, etc. for which the patient need not be hospitalized or need not be admitted to hospital for a long time.

*3: "Material damage" means additional damage originating from the failure of assets and materials, and involving livestock and pets.

Description of symbols

Symbol	Meaning of symbol
 Prohibition	"⊘" indicates prohibition (a forbidden action). The practical detail of the danger is depicted in the form of an image or a sentence within or near the symbol.
 Mandatory Action	"●" indicates a mandatory action (a compulsory action). The practical detail of the danger is depicted in the form of an image or a sentence within or near the symbol.

Important notes:

Be sure to observe all safety precautions marked with the DANGER, WARNING and CAUTION labels, and do not do anything that is not described in this manual in order to avoid injury, death or property damage.

Disclaimer

Toshiba shall not be responsible for any breakdowns or accidents caused by inappropriate management or usage, including but not limited to the following:

- Failure to follow or apply the operating or handling instructions contained herein
- Inappropriate maintenance, inspections and/or repairs
- Unauthorized alterations to the escalator
- Use of parts other than those provided or specified by Toshiba

Safety Precautions

The following precautions apply to the Owner and the Operator of elevators.

WARNING

■ **Perform a daily inspection (refer to page 25)**

Perform a daily inspection to avoid undesirable malfunction or risk of accident.



Mandatory Action



■ **Carry out regular and preventive maintenance.**

Conduct regular inspections and maintenance on the elevators to detect and prevent problem before occurrence. Please contact TOSHIBA for further details.



Mandatory Action

■ **Stop the escalator immediately in the event of failures, when smoke is emitted or there is any strange sound etc.**

(refer to page 16 for how to stop).

Stop the operation Else, this may result in a fire or fault. Please contact the maintenance service company immediately.



Mandatory Action

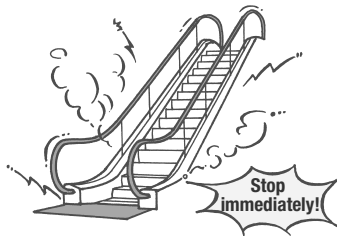

■ **When water penetrates due to heavy rain etc., stop the operation immediately (refer to page 16 for how to stop).**

Continuing operation under such circumstances may lead to undesirable accident. Please contact the maintenance service company after shutting down the operation.



Mandatory Action



■ **Do not repair, remodel or disassemble.**

This may result in electric shock, serious injury, or fault. Please contact our company if there are any problems occur.



Prohibition

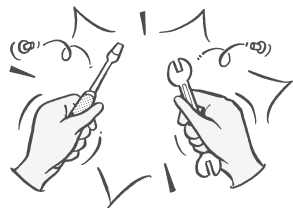

■ **Do not pour liquids, such as water, or apply wax etc. on the step and/or landing plate.**

This may increase the risk of slipping on the steps and landing plate surface, which may lead to undesirable accident.

Besides, leakage of liquids into escalator may result in electric shock or malfunction.



Prohibition



■ **Do not remove the landing plate.**

Since it houses a control panel, motor, etc. inside, this may result in undesirable accident.



Prohibition

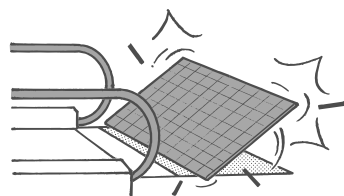

■ **Do not operate key switches with wet hand.**

This may result in undesirable accident.



Prohibition

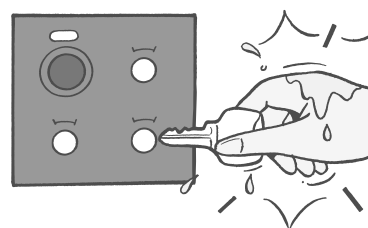

Safety precautions to be observed (Continued)

The following precautions apply to the Owner and the Operation Supervisor of escalators.

WARNING

- **Ensure the escalators are free of passengers and/or object before starting and stopping it.**
If it is made to start and stop, with a person or object present, this may result in undesirable accident.



Mandatory
Action



- **Stop the escalator before cleaning and maintenance (refer to page 16 for how to stop).**
Failure to do so may result in undesirable accident.



Mandatory
Action



- **Do not hold an event which may create crowd around the landing plate from the escalator.**
The crowd will prevent passengers from getting off from escalator and lead to undesirable accident.



Prohibition



- **Do not use stopped escalator as seats.**
It will descend due to overloading, which may result in undesirable accident.



Prohibition



- **If any work that is involved of fire/sparks/heat please provide adequate instructions for fire prevention to the responsible personnel of the work.**
Sparks produced from the work may get into escalator and causing undesirable accident.



Mandatory
Action

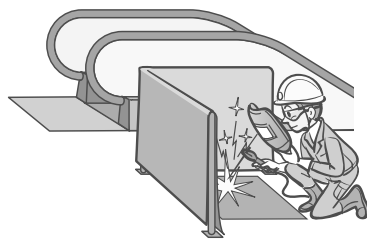

Mandatory
Action

- **Set up barricades when you suspend the escalator services to prevent people from using the escalators like staircases. Else, undesirable accident may occur.**
Otherwise, a trip or fall accident may occur.



Mandatory
Action

- **Affix warning labels at places where the passengers can notice them easily.**
Passengers should be alerted to prevent accidents and breakdowns.
The operation supervisor should show users how to ride an escalator.

Please guide passengers with the following instructions:

! DANGER

■ Do not get on the handrail and deck board.
This may cause undesirable injuries and accident.



Prohibition



■ Do not lean your body (body parts) out of the handrail, or lean against a handrail.
The head may hit a wall etc., or be pinched, causing upset or failure.



Prohibition



! WARNING

■ Do not ride the escalator with wheelchairs, baby carriages, and shopping carts, etc.
This may lead to undesirable accident.



Prohibition



■ Do not run or walk on the steps.
There are possibilities of accident occurrence.



Prohibition



■ Do not run on and off the step.
It may lead to undesirable accident.



Prohibition



■ Do not lean against glass (or a panel).
It may lead to undesirable accident.



Prohibition



■ Do not allow children to play around the escalators.
This may lead to undesirable accident.



Prohibition



■ Do not touch the step, comb, skirt guard panel, or handrail inlet with hand.
This may lead to serious injury and undesirable accident.



Don't touch



Safety precautions

Please guide passenger with the following instructions:

WARNING

■ **Do not climb or walk on the deck board.**
It may lead to undesirable accident.



Prohibition

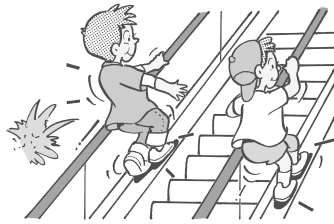

■ **Do not use escalator in the event of a fire and/or earthquake.**
It may lead to a second accident.



Prohibition



■ **Small children must be accompanied and have their hand hold by the guardian.**
Negligence may lead to undesirable accident.



Mandatory action



■ **Do not pull a handrail or kick away the skirt guard panel etc.**
A safety device may trigger an emergency stop, or result in unsynchronized motion of handrail and steps, causing undesirable accident.



Prohibition



■ **Stand within the yellow line.**
If you stand on the yellow line, there are possibilities of injuring your feet.



Mandatory action

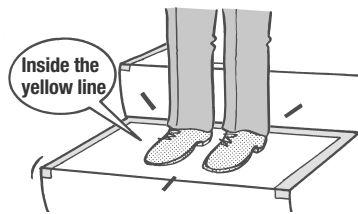

■ **Do not ride with clothes that possible to be caught by the escalator such as long skirts.**
The skirt may caught by the escalator and lead to undesirable accident.



Prohibition



■ **Hold the handrail firmly.**
This would help to prevent the occurrence of undesirable accident.



Mandatory action



■ **When small children get on, their parent or guardian needs to hold their hand.**
If their hand is not held or they use the escalator alone, this may result in an accident.



Mandatory Action



Please guide passengers with the following instructions:

! WARNING

- Do not step on the comb when you are getting on or off an escalator.

Failure to do so may lead to undesirable accident.



Mandatory Action



- Escalators with a width of 1000 mm allow up to two passengers to stand on the same step (while those with a width of 600 mm and 800 mm allow only one passenger on the same step). Accident has higher possibility to occur on a crowded escalator, passengers should leave a sufficient space between themselves.

Otherwise, passengers may fall, or unexpected accidents may occur.



Mandatory Action



! CAUTION

- Do not carry large baggage on the escalator.

The passenger may tumble down with the baggage, or the baggage may hit the other passengers, which result in undesirable accident.



Prohibition



- Do not place any package etc. on the step, handrail, deck board, or landing plate.

The package etc. may fall, and cause serious injuries and undesirable accident.



Prohibition

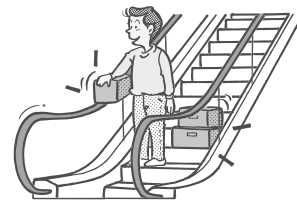

- Do not carry any long objects.

The passenger may lose balance, leading to undesirable accident. In case, the object is stuck between a moving escalator and the ceiling, will cause damage to steps and undesirable accident.



Prohibition



- Do not use a stopped escalators as a staircase.

This may lead to undesirable accident.



Prohibition



Safety Precautions

Please guide passengers with the following instructions:

CAUTION

- **Do not sit on the steps.**
It may cause serious injuries.



Prohibition



- **Do not take animals.**
It may lead to undesirable accident.



Prohibition



- **Do not stop at the landing plate once getting off from the escalator.**
The way of other passengers will be blocked, causing undesirable accident.



Prohibition



- **Do not touch steps with thin or pointy objects, such as the point of an umbrella.**
It may become caught in a groove, which may lead to an accident or failure of a step.



Prohibition



- **Do not smoke while riding an escalator.**
This may lead to undesirable accident.



Prohibition



- **Do not get on escalator with wet shoes, or hold a handrail with wet hands.**
Slippery steps and handrails may lead to undesirable accident.



Prohibition



- **Do not force the head or heels of footwear of soft material, such as rubber or vinyl products, into the clearance between skirt guard panels or steps.**
This may cause accident if the object is caught between a skirt guard panel or step.
Moreover, this will trigger the safety device and emergency stop, which may lead to undesirable accident.



Prohibition

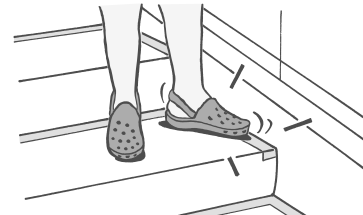

Please guide passengers with the following instructions:

CAUTION

- **Be careful for not letting your stiletto heels to be caught between the escalator steps.**

Stiletto heels may stuck in between the groove or comb, leading to undesirable accidents.



Mandatory
Action

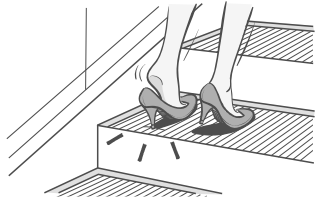

- **Do not ride the escalator with barefoot.**

This may lead to serious injuries.



Prohibition



The Safety Devices

Safety devices in “Kindmover” (TE type escalator).

Kindmover (TE Type Escalator)

All of these safety devices trigger emergency stop. To resume the operation, please refer to page 19.

Skirting brush (option)

Skirt guard panel safety device

When a foreign substance is caught between the steps and the skirt guard panel, the device will be triggered and stop the escalator immediately. (In Hongkong, this device is installed at the middle of escalator.)

Comb safety device

Emergency stop button

In case of emergency, stop the escalator immediately by pressing this button.

Handrail inlet safety device

If there are any foreign objects caught in the handrail inlet, the device will be activated and stop the escalator.

Broken step chain detection device

When the step chain is stretched excessively or broken, the device will stop the escalator immediately.

Step abnormality detection device

If the steps run abnormally, the device will stop the escalator immediately.

Step safety device

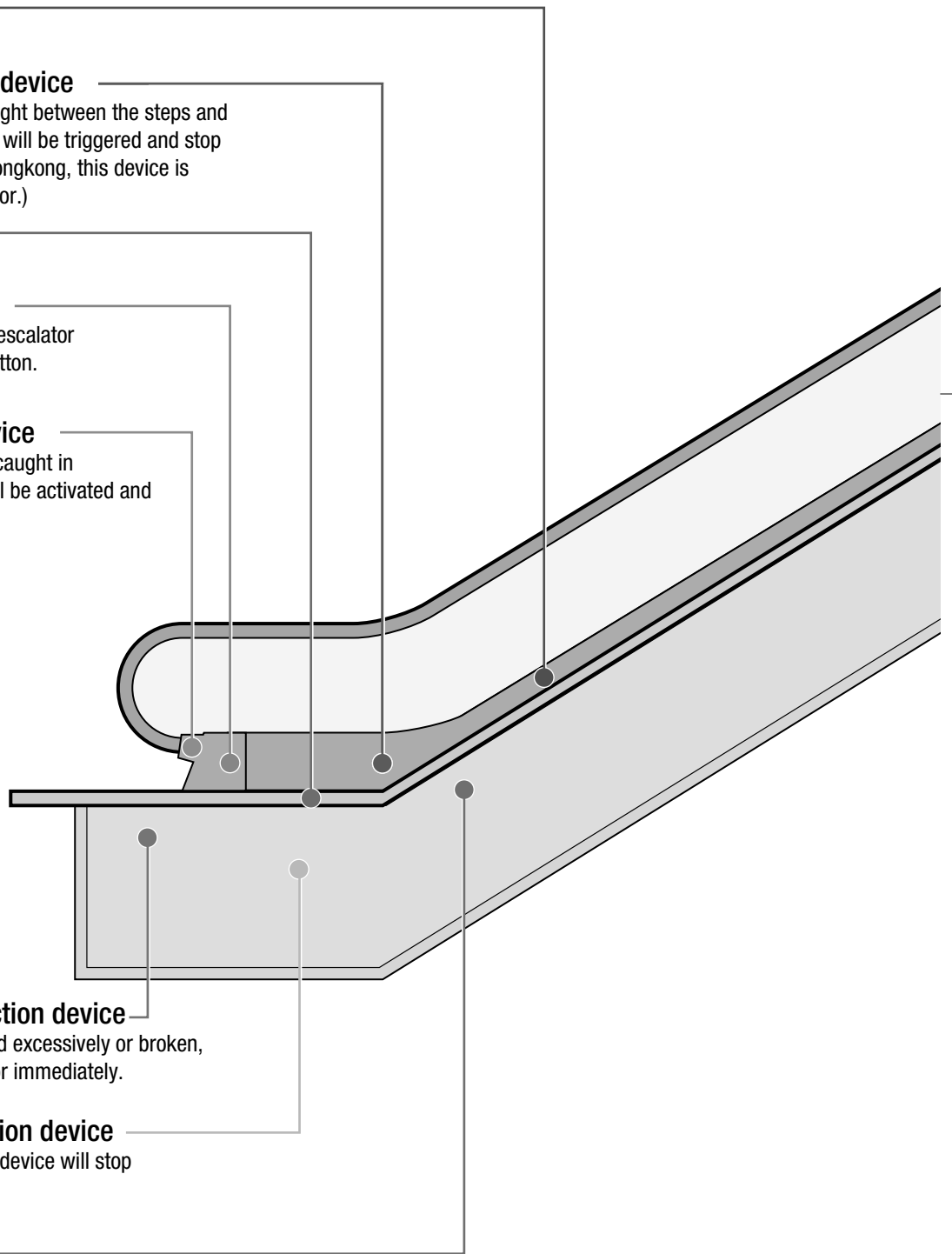

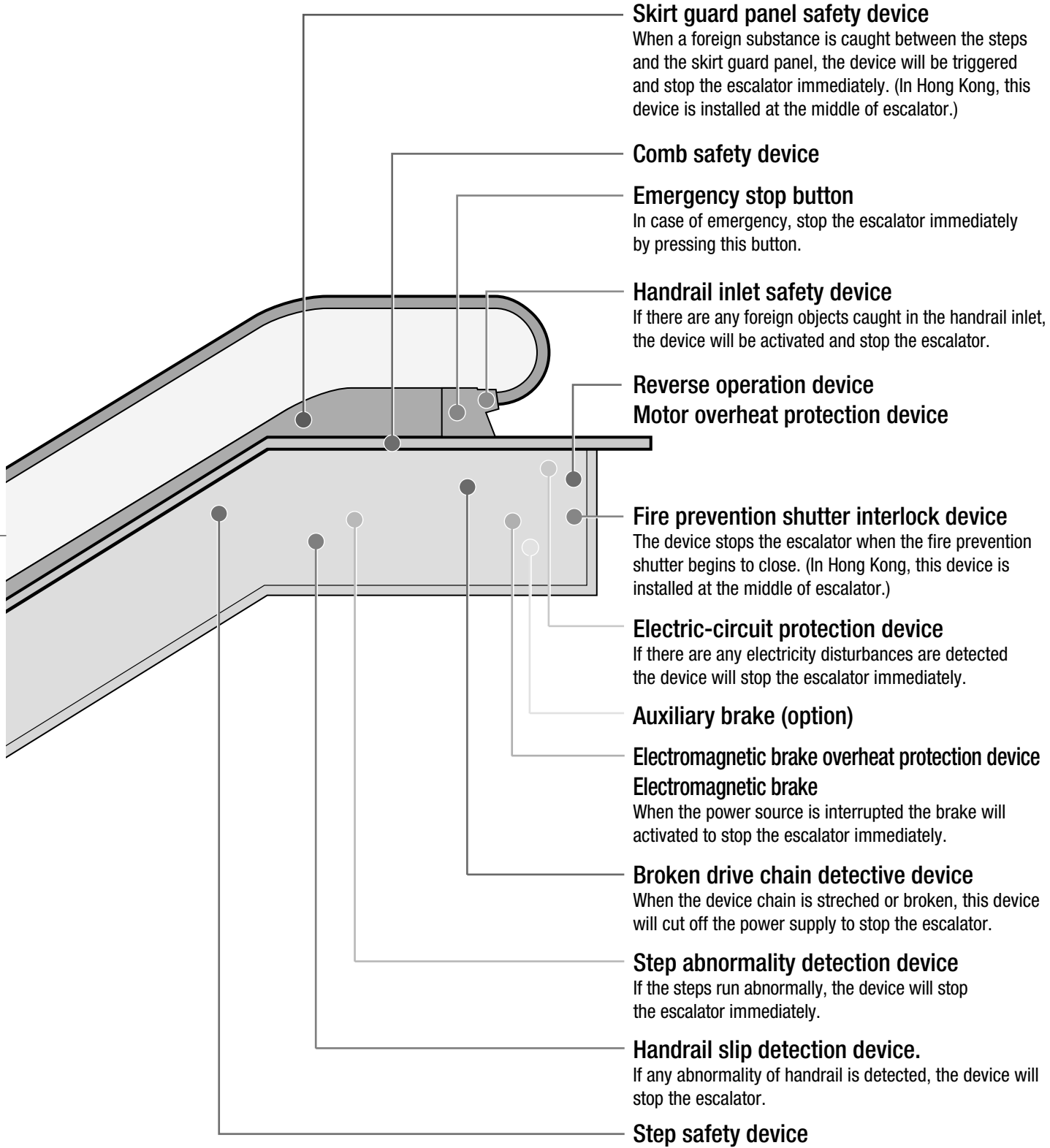

Name and Function of Escalator's Part

**Warning labels
(Getting down Area)**

Fixed protection plate

Wedge guard

This is a protection plate which alert the passengers of the danger of leaning out from the escalator. Also, it prevents passengers from being caught in between the ceiling and escalator.

Handrail

Step

Accommodate and carry passengers.

Yellow Demarcation Lines

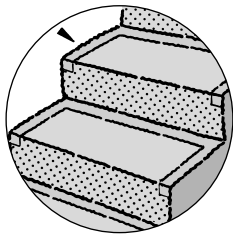

Balustrade lighting

<D-Type>

ESNAVI
<Option>

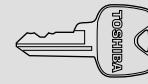

Operation key

To start or stop an escalator.
The operation key should be keep by authorized person only

Deck board

**Warning labels
(Getting on Area)**

Handrail inlet

Front skirt

Comb

Prevents any foreign substances from being caught in the joint of a landing plate and a step.

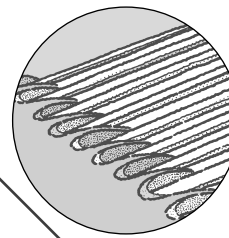

Skirt guard panel

Landing plate (floor plate)

Symbol	Operation part name	Explanation
A	Emergency stop button	In case of emergency, stop the escalator immediately by pressing this button. The emergency stop button has a protective cover around it to prevent inadvertent operation. Press the emergency stop button firmly at the center of the cover.
B	UP/DOWN key switch	Select the moving direction by turning the UP/DOWN key switch.
C	STOP/BUZZER key switch	Turn the switch to stop the escalator or to sound a buzzer.
D	Lighting/lights-out key switch (Only the lower floor operating panel of the D-Type)	Turn on or turn off the lighting system.

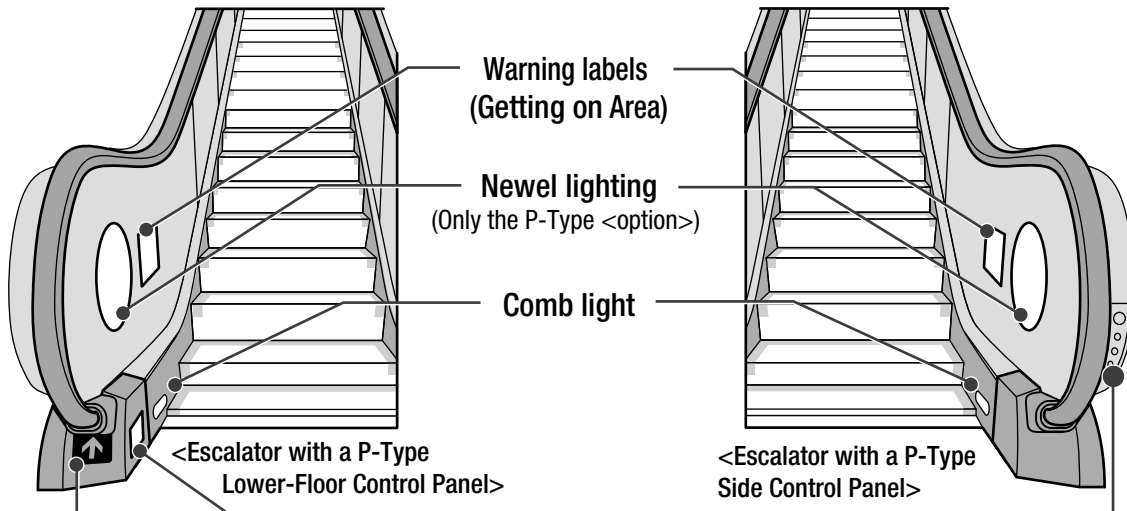

ESNAVI
<Option>

Upper floor operating panel
<D-Type, S-Type, P-Type>



Lower floor operating panel
<P-Type>



Lower floor operating panel
<D-Type, S-Type>

(Lighting/lights-out key switch is only the D-Type)

Side Control Panel
<P-Type>

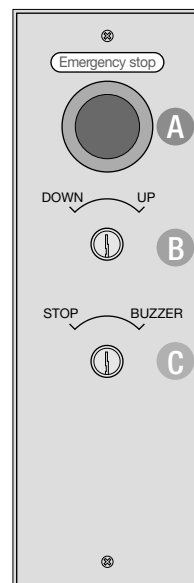

Operating Procedures

WARNING

- **Before starting or stopping the escalator operation,** make sure that there are no passengers on the escalator, and that there are no objects placed on the escalator.
Starting or stopping the escalator when there are passengers on the escalator could cause the passengers to fall or tumble, may lead to death or serious injury.
- **Remove the key and return it to the in-charge person after the operation is completed to prevent unexpected accident.**
- **Do not operate keys and switches with wet hand.**
There is possibility of electric shock if water reaches internal electrical components from the operating keys, which may lead to death or serious injury. This could also cause equipment failures or breakdown.

Start up

1

Make sure that there are no passengers on the escalator, and that there are no objects placed on the escalator.

- If anyone is on the escalator, wait until they have gotten off.
- If any objects are placed on the escalator, remove them.
- If the escalator is interlocked to fire-proof shutters, make sure that the fire-proof shutters are completely open.



2

Turn the operating panel STOP/BUZZER switch to the "BUZZER" position.

- The alarm sounds, informing anyone in the vicinity that escalator operation is about to begin.
- If the alarm does not sound, contact the maintenance service company.

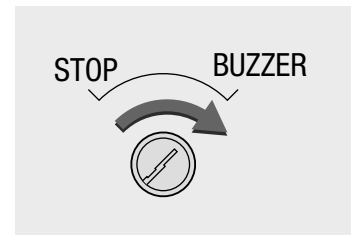

3

Turn to the desired direction of operation via the up/down key switch.

- If the escalator has lighting system installed, all of them will turn on at the same time.
- ESNAVI is used to display the moving direction of the escalator to the passengers. Please refer page 18 th for further details of ESNAVI.

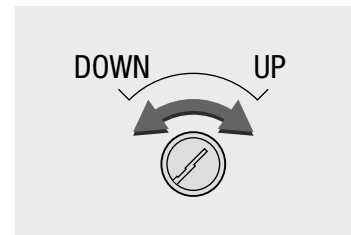

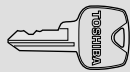

Operation key

Use to start or stop an escalator.
The operation key should be kept by authorised person only.

Shutdown

1

Make sure that there are no passengers on the escalator.

- If passenger is present, please wait for the person to get off from the escalator.



2

Turn the operating panel STOP/BUZZER key switch to the "BUZZER" position.

- The alarm sounds is to alert the people around that escalator operation is about to stop.

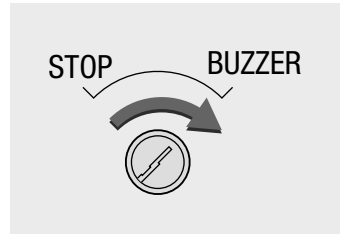

3

Turn STOP/BUZZER key switch to the "STOP" position.

- The escalator will stop.
- If the escalator has lighting system and ESNAVI installed, all of them will turn off at the same time.

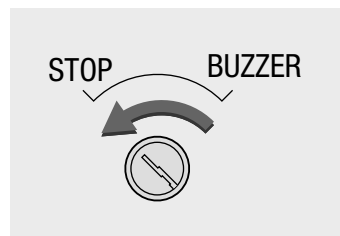

How to Ride an Escalator Safely

Please also read the safety precautions (refer to the page 3) and observe the right methods to use escalators (refer to the page 4 to 10) to the users via notice or announcements, etc. Please guide users directly, especially during rush hours.

1

Always stand within the yellow demarcation line of the step.

- If you stand on the yellow line, you may get your feet caught between a moving step and the skirt guard panel, or between the steps.

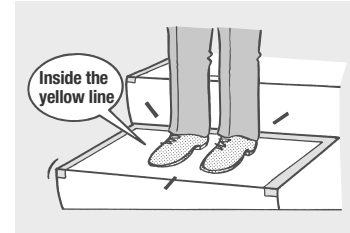

2

Hold the handrail firmly.

- Hand of small children must be hold by the guardians.



3

Do not run or walk on the escalator.

- Escalators are not staircases; running or walking on escalators may lead undesirable accident.



4

Step over the comb when you get on/off the escalator.

- Give instructions to passengers, so they can get on and off the escalator safely especially for children, elderly and disabled passengers.



Attention to The Owner and The Operator

Escalators with a width of 1000 mm allow up to two passengers to stand on the same step while those with a width of 600 mm and 800 mm allow only one passenger on the same step. To avoid tripping or unexpected accidents due to contacts of passengers or with baggage, please make sure that passengers allow a proper space in front and behind them.

When the escalator is crowded with passengers, please give instructions to or restrict the flow of passengers to have them keep a proper space in front upon getting on the escalator to prevent crowd at the landing area. If the landing area is crowded, stop passengers from getting on the escalator immediately to avoid undesirable accident.

Definition of ESNABI's signals

< Option >

- ESNABI indicates the moving direction of the escalator before passengers get on an escalator.
- When a safety device is activated, the escalator will be stopped, ESNABI will indicate the position of safety device to enable the maintenance staff to find out the problem quickly.

When the escalator is operates normally

Signal of getting on an escalator



: Displays the direction of movement (green, scrolling).

Signal of getting off an escalator



: Display no entry sign (red, flickering).

ESNAVI <Option>



When problem is detected the escalator stops

Displays the following example display and the no entry mark alternately.

The display of a getting on port/ getting off port

ES : "Emergency stop button is activated. (green)"

HS : "Handrail speed monitoring device is activated (green)"

IN1 / **IN1** : "Upper floor handrail inlet safety device is activated (red/green)"

IN2 / **IN2** : "Lower floor handrail inlet safety-device is activated (red/green)"

SK1 / **SK1** : "Safety device for the upper floor skirt guard panels is activated (red/green)"

SK2 / **SK2** : "Safety device for the lower floor skirt guard panels is activated (red/green)"

CM1 / **CM1** : "Upper floor comb safety device is activated. (red/green)" <Optional>

CM2 / **CM2** : "Lower floor comb safety device is activated. (red/green)" <Optional>

SE1 / **SE1** : "Upper floor step safety device is activated. (red/green)"

SE2 / **SE2** : "Lower floor step safety device is activated. (red/green)"

SH / **SH** : "Fire prevention shutter interlocking device is activated. (red/green)" <Optional>

HT "Electric-circuit protective device"/ "broken driving chain safety device"/ "brocken step chain safety device", etc. (red) is detected.

When the emergency stop is activated for one of 7 possible mentioned factors, ESNABI displays the cause of abnormalities etc. in "red". If abnormalities are fixed by suitable measures and normal operation is enabled, the display color of ESNABI will turn to "green"

Safety Measures in Case of Emergency

In Case of Emergency Stop

When the emergency stop button is pressed or a safety device had been activated, please follow the procedures stated below:

[Where ESNAPI is not applied]

1

Inspect the handrail inlet, front skirt, comb, step, skirt guard panel, etc.
(Refer to page 25 for the checking method)

- If any foreign object or problem is found, please contact the maintenance service company.
- If case of accident results in injury or death, please refer to page 20.

2

Start the escalator. (Refer to page 15 for how to start)

- In case you are unable to start the escalator, please contact the maintenance service company.

[Where ESNAPI is applied]

1

● Please refer to page 18 for the definition of ESNAPI's signs.
Inspect the handrail inlet, front skirt, comb, step, skirt guard panel, etc.
(Refer to page 25 for the inspection method)

- Please identify the cause of the emergency stop via ESNAPI. (Please refer to page 18 for definition of the ESNAPI's signs)
- If any foreign object or problem is found, please contact the maintenance service company.
- In case of accident results in injury or death, please refer to page 20.

2

Check if the display color of ESNAPI has turned to green.

- When the cause of an emergency stop is solved, the display color of ESNAPI will turn to green. Escalator is able to restart.
- If the display color does not turn to green, please do not restart the escalator. Please contact the maintenance service company immediately.
- In case of **HT**, escalator can not restarted, please contact the maintenance service company.

3

Start the escalator. (Refer to page 15 for how to start)

- In case you are unable to start the escalator, please contact the maintenance service company.
- In case it stops frequently for the same cause after restart, or immediately after restart,
- please contact the maintenance service company.

In Case of Accident Results in Injury or Death Occurs

Stay calm and take action according to the following procedures:

Please contact the police/fire service, and maintenance service company immediately.

1

Press the emergency stop button immediately.

- The escalator stops.

2

Take the possible safety measures to rescue the victim(s).

- Please contact the fire station if the rescue is impossible, and in case of serious injury.
- Pay attention during the rescue operation and keep unauthorized people away from the spot.

3

Contact the maintenance service company.

Example of the rescue method

■ When fingers were caught in the handrail inlet.

Use tools (driver etc.) to help the victim to draw out his/her fingers from the handrail inlet.

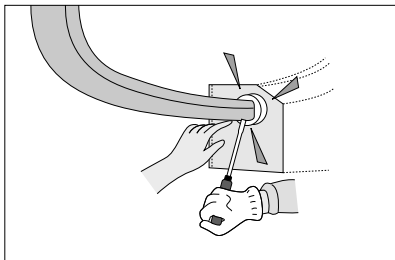

■ Hand and/or foot are caught in between the comb.

Remove the comb with a screwdriver.

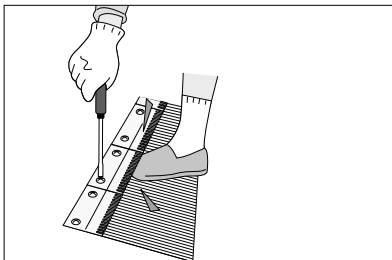

■ The foot is caught in between the step and the skirt guard panel.

Use tools (bar, etc.) to widen the clearance between the skirt guard and step.

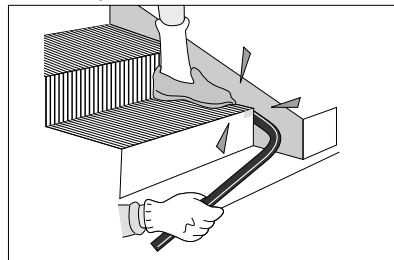

- These rescue methods are examples. The rescue may be difficult depend on situation. In such cases, please seek for professional help.

Safety Measures in Case of Disaster

In case of disaster, it is very important for the supervisors to assess the situation calmly, take action promptly, and always ensure user's safety.

Here, we explain the procedures to be taken in times of disaster.

In Case of Earthquake

DANGER

- Please do not use the escalator in case of earthquake.
Taking refuge on an escalator may lead to secondary accident.

WARNING

- When you suspend the escalator services, put up barricades to prevent people from climbing up or down escalators like staircases to prevent undesirable accident.
Otherwise, a trip or fall accident may occur.

1

Notify passengers about the occurrence of an earthquake by making announcement, and direct alert them for not to use the escalator.

- Please guide the passengers, so they can take refuge safely.

2

Stop the escalator. (Refer to page 16 for how to stop)

3

Carry out daily inspection, after the earthquake has subsided.
(Refer to page 25)

- In any problem is detected, please contact the maintenance service company.
- If no problem found, please resume the operation (refer to page 15 for how to start).

In Case of Fire

DANGER

- Please do not use the escalator in case of.
Taking refuge on an escalator raises the potential of secondary accident.

WARNING

- When you suspend the escalator services, put up barricades to prevent people from climbing up or down escalators like staircases to prevent undesirable accident.
Otherwise, a trip or fall accident may occur.

1

Notify passengers about the outbreak of fire by making announcement, and alert them for not to use the escalator.

- Please guide the passengers, so they can take refuge safely.

2

Notify the fire station immediately.

- Please also contact the maintenance service company.

3

Stop the escalator. (Refer to page 16 for how to stop)

- A fire prevention shutter may be activated, which will stop automatically.

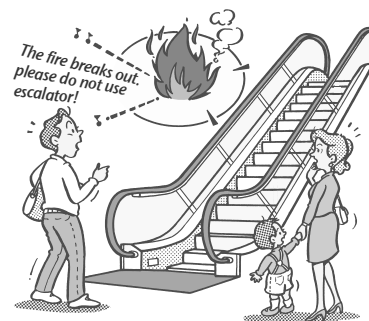

Safety measures in case of disaster (continued)

Power Outage Notification

WARNING

- When you suspend the escalator services, put up barricades to prevent people from climbing up or down escalators like staircases to prevent undesirable accident.
Otherwise, a trip or fall accident may occur.

1 Notify users of the power outage via notice and announcement etc. in advance.

2 Stop the escalator, before the power is cut off.
(Refer to page 16 for how to stop)

3 Resume the operation, after the power is restored.
(Refer to page 15 for how to start)

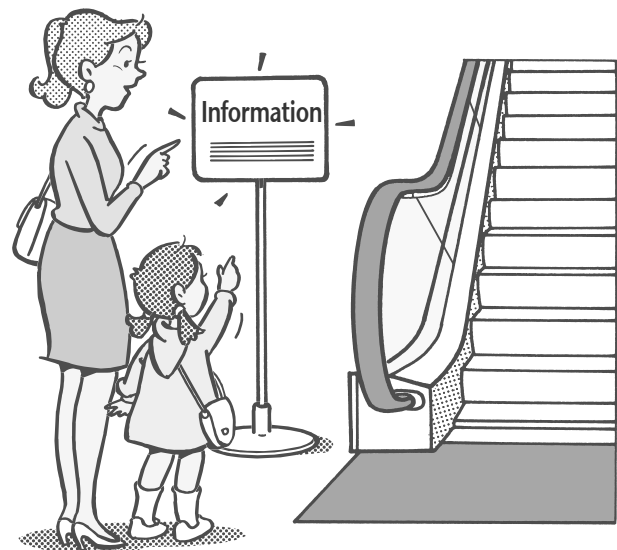

In Case of Rainstorm

DANGER

- If water penetrates into the escalator due to heavy rain etc., please stop the escalator immediately (refer to page 16 for how to stop).

Continues the operation may lead to undesirable accident. If the equipments /parts have been soaked into water, replacement may be required

WARNING

- When you suspend the escalator services, put up barricades to prevent people from climbing up or down escalators like staircases to prevent undesirable accident.

Otherwise, a trip or fall accident may occur.

In case of Rainstorm (Possibility of Water Leakage)

1

Stop the escalator (Refer to page 16 for how to stop).

- When there is possibility of water leakage, please stop the escalator.

2

Create a dyke to prevent water from flowing in to the escalator.



[After the Rainstorm]

1

Check the landing plate to ensure there is no trace of any water having penetrated into the escalator.

- If any of water trace is detected, please stop operation and contact the maintenance service company (refer to page 16 for how to stop).
- If there is not trace of water leakage, please resume the operation (refer to page 15 for how to start).
- Although the outdoor escalators are designed to withstand certain extent of rainstorm. but we would recommend you to stop it in advance, like a normal escalator during rainstorm.

[If any parts of the escalator had been soaked in water during operation]

1

Please stop the operation immediately and contact the maintenance service company.

- Please do not resume operation under any circumstances unless procedures such as the insulating measurement test etc. draining, dryness check have been done by an authorized technician.

Procedure for Daily Inspection

 **DANGER**

■ **Please conduct daily inspections.**

Conduct regular inspections daily to prevent undesirable problem and accident.
Operation with safety comprised may lead to undesirable accident.

Please conduct the following inspection everyday.

If anything unusual occurs, please contact the maintenance service company.

Please check the surrounding facility installation situation at the time of test runs and round checks.

If the safety equipment is deficient, or any obstacle exists, do not operate the escalator under any circumstances.

Inspection		Content of inspection
①	Operational status	<ul style="list-style-type: none"> • Ensure there is no sign of abnormal sound. • Ensure there is no sign of abnormal vibration.
②	Handrail	<ul style="list-style-type: none"> • Ensure there is no sign of abnormal flaw. • Match the step speed. • Ensure there is no sign of abnormal vibration.
③	Handrail inlet safety device	<ul style="list-style-type: none"> • Ensure there is nothing missing or damaged. • Ensure nothing is caught.
④	Front skirt	<ul style="list-style-type: none"> • Ensure there is nothing missing or damaged. • Ensure nothing is caught.
⑤	Comb	<ul style="list-style-type: none"> • Ensure there is nothing missing or damaged. • Ensure nothing is caught.
⑥	Step	<ul style="list-style-type: none"> • Ensure there is nothing missing or damaged. • Ensure nothing is caught.
⑦	ESNAVI <Optional>	<ul style="list-style-type: none"> • Ensure there is nothing missing or damaged. • Ensure it display operates normally or does not blink.
⑧	Skirt guard panel	<ul style="list-style-type: none"> • Are not in contact with a step. • Ensure the clearance between steps is not excessive. • Ensure nothing is caught.
⑨	Glass panel/Deck board	<ul style="list-style-type: none"> • Ensure no damage.
⑩	Lighting (only the D type) Skirt guard panel lighting <Optional>	<ul style="list-style-type: none"> • Ensure it operates normally or does not blink. • Ensure that there is no damage or crack on the acrylic cover of the skirt guard panel lighting. • Ensure the skirt guard panel lighting is operates normally and not flickering.
⑪	Wedge guard	<ul style="list-style-type: none"> • Ensure no damage. • Ensure it does not shift.
⑫	The partition plate for ingress prevention	<ul style="list-style-type: none"> • Ensure no damage. • Please provide partition plate prevent the passengers from falling from the clearance between the balustrade and the fall prevention fence, etc. in a landing place.
⑬	Falling object prevention net	<ul style="list-style-type: none"> • In order to catch falling objects, to prevent accident, please install a net for protection etc. in the middle blow-by part.
⑭	Speaker	<ul style="list-style-type: none"> • It is effective if you use announcements over a store's public address system etc. for guidance, PR, etc. concerning the right method of getting on and off escalators.
⑮	Fall prevention fence	<ul style="list-style-type: none"> • Please install a fence around the escalator to prevent a small child nor any object from falling accidentally.

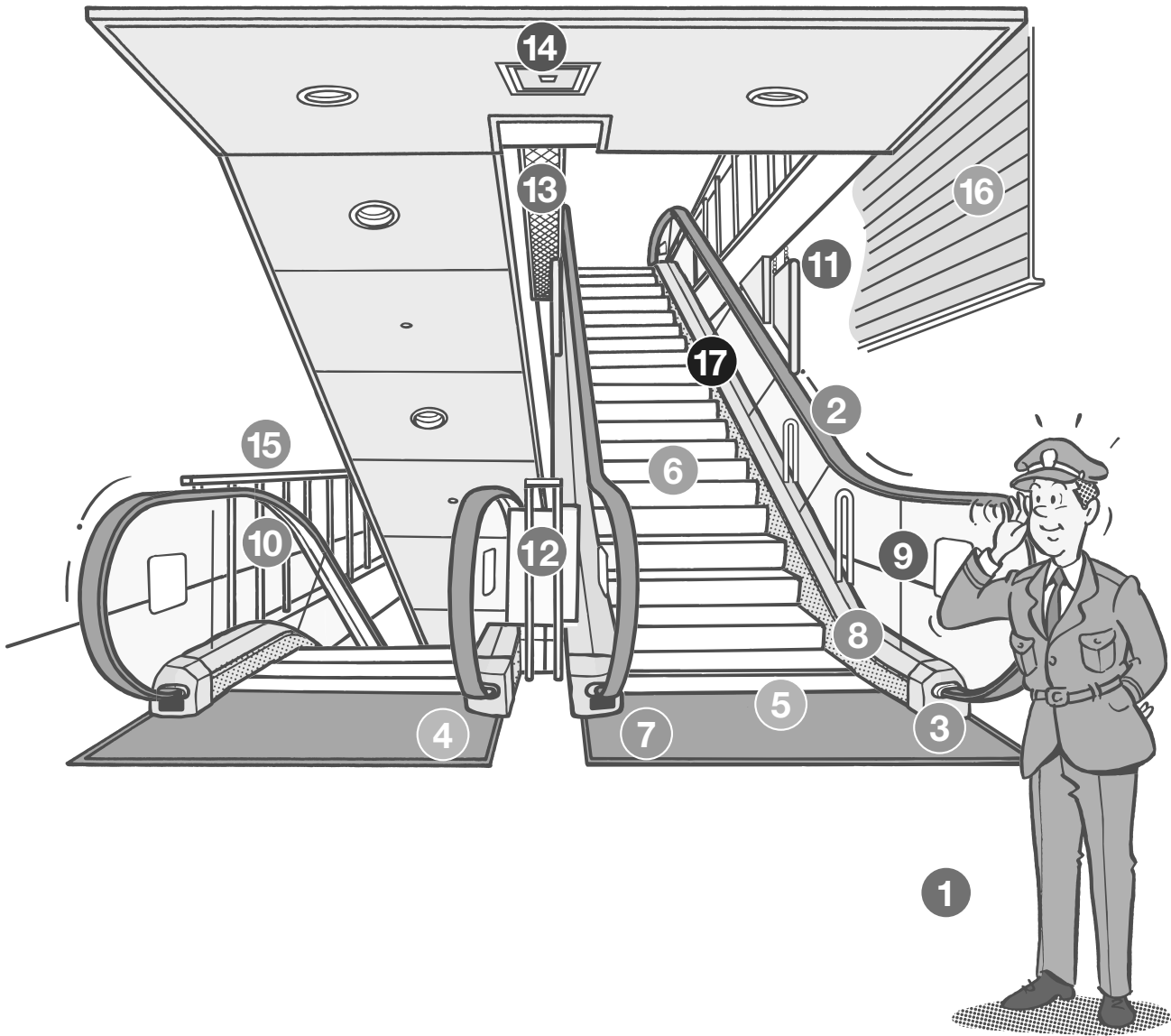

Procedure for Daily Inspection

Inspection	Content of inspection
16 Fire prevention shutter interlock device	<ul style="list-style-type: none"> In the event of fire, it is needed to isolate the escalator from the outside.
17 Deflector	<ul style="list-style-type: none"> Ensure no damage. Ensure it does not shift.

- Please remove any object that triggered emergency stop in 3, 5, 6 and 8 (refer to page 13 for how to stop).
- 7, 10 and 11 are optional, depend on situation.

How to Clean Up and Maintain

! DANGER

■ Please do not pour liquids, such as water, or apply wax etc. on the step and/or landing plate.

This may increase the risk of slipping on the step and landing plate surface, which may lead to undesirable accident. Besides, leakage of liquid into escalator may result in electric shock or malfunction.

■ Please stop the escalator before cleaning and maintenance (refer to page 16 for how to stop).

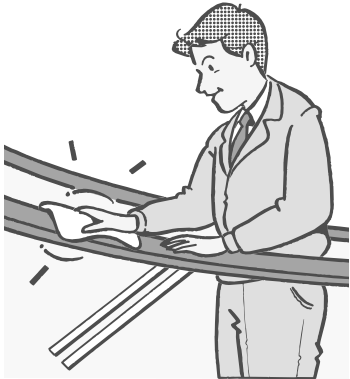
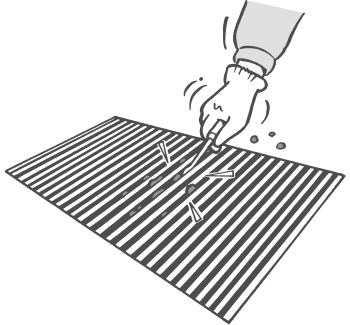

Failure to do so may result in undesirable accident.

Cleaning area	The cleaning method	
Handrail	<ul style="list-style-type: none"> • Wipe with a dry soft cloth. • Wipe stubborn stain with neutral detergent diluted to about 1%. Remove the moisture with dry cloth later. After the handrail dries, please apply slide agent* with a cloth to the handrail surface. When the liquid dries, please wipe with a dry cloth. Keep in mind that the handrail may get scratched if it is neglected or over-wet with too much silicone. ● Stop the escalator. Clean only the exposed portion of the handrail. When the cleaned section is thoroughly dried operate the escalator to expose a remaining section and continue with the cleaning operation. <p>*An example slide agent Toshiba Silicone emulsion TSM 630 <GE Toshiba Silicones Co., Ltd.></p>	
Comb Step Landing plate	<ul style="list-style-type: none"> • Remove rubbish etc. with a vacuum cleaner. • Remove any rubbish the groove of the comb or step. 	

Note

Please do not use benzene, a thinner, a gasoline, etc.

These solvent may cause degradation and discoloration of escalator material..

Cleaning area	The cleaning method	
Glass panel Deck board	<ul style="list-style-type: none"> • Wipe with the dry soft cloth. Wipe stubborn stain with neutral detergent diluted to about 1%. Remove the moisture with dry cloth later. ● Please read the instruction manual for how to use the glass cleaner. 	
Illumination cover ESNavi Front skirt	<ul style="list-style-type: none"> • Wipe the stain with neutral detergent diluted to about 1% strength. • Occasionally, wipe of the stain with plain water. Remove the moisture with dry cloth and apply anti static agent. ● Users should read the instruction manual for how to use the antistatic agent. 	



DANGER

- Please apply a slide agent to the skirt guard panel once or twice a month.
Inadequate slide agent may cause the shoes etc. to become drawn into the clearance between the step and skirt guard panel.
- Please do not allow the slide agent adhere to a step.
Else it may lead to undesirable accident.

Cleaning area	The cleaning method	
Skirt guard panel	<ul style="list-style-type: none"> • Please apply a slide agent once or twice a month. (When a fluoro-resin coating skirt is used, please apply about once every three months.) <p>An example slide agent Toshiba Silicone emulsion TSM 630 <GE Toshiba Silicones Co., Ltd.></p>	

Note

Contact Toshiba when you need to dispose of or move escalators.

Guidelines on the Maintenance and Operation of Escalators

 **DANGER**

■ **Please implement legal regular inspection and maintenance checks.**

The escalators should be inspected and maintained regularly to ensure the safe use of escalators and its performance.

Please consult with our company regarding the inspection and maintenance.

■ **The oil etc. used for lubrication may accumulate in the lower truss of the escalator.**

Please conduct regular inspection to prevent oil leakage problem.

Therefore, be careful regarding the following:

- Please do not enter into any maintenance contract with any unauthorized / unqualified maintenance company.
- Please do not engage in the recovery of oil by any means other than through a maintenance operator.
- Please dispose of recovery oil properly to avoid environment pollution.

As described above, escalators must be a safe means of transportation that can be used conveniently in our daily life. Of course, to ensure safety, the equipment itself must be designed to be safe, but at the same time, it should also be properly used and maintained.

In order to prevent accidents and ensure safety, the owner and the operation supervisor of escalators should fully understand them and perform daily maintenance and operation properly.



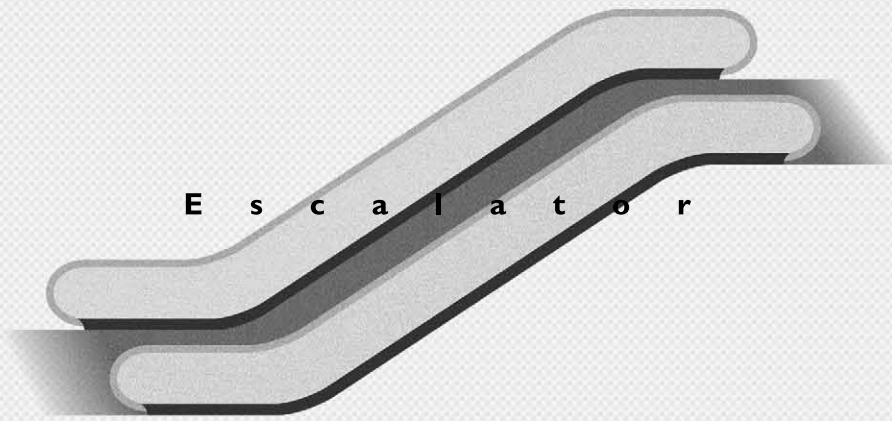

E s c a l a t o r

The specification and external appearance would be changed for its improvement without notice.